

A PORTABLE SHOCK AND ENVIRONMENTAL RECORDING SYSTEM

By Allen D. Diercks, Endevco Corporation

INTRODUCTION

In recent years it has become evident that there is a serious need for significant data on shock and environmental conditions encountered by sensitive equipment during transportation. Available data accumulation techniques range from simple mass/friction devices (which indicate only that a given shock level has been exceeded) to sophisticated analog and digital systems. The simple devices seldom record sufficient data to allow a meaningful analysis while the more sophisticated systems tend to be limited to the recording of one aspect of the total environment. The system presented in this paper is designed to accommodate the accumulation of both significant shock data and environmental data of a more static nature.

CRITICAL COMPONENTS

Before considering the total system it is best to discuss some of the more critical components since their constraints govern the performance of the over-all device. For example, a seven channel, incremental, digital tape recorder was selected as the recording method. The compact recorder provides 300 feet of tape in an easily replaced cartridge and an IBM compatible character density of 200 characters per inch. The ability to easily process the information on the tape by using IBM equipment and standard data processing techniques had much influence on the selection of this recording method.

The compromises in any recording method are between storage capacity, resolution, and ease of processing. The storage capacity of 720,000 seven bit numbers is adequate for most purposes since it allows recording of more than 100,000 sets of data. Numbers

Reprinted by Endevco Corporation from
The Institute of Environmental Sciences
1966 Annual Technical Meeting Proceedings

Page 1 of 9
11/66

ENDEVCO CORPORATION • 801 SO. ARROYO PARKWAY • PASADENA, CALIF. 91109 • TELEPHONE (213) 795-0271
Akron, Ohio • Albuquerque, New Mexico • Boston, Massachusetts • Chicago, Illinois • Houston, Texas • Huntsville, Alabama • Mountain View, California
Palo Alto, California • Philadelphia, Pennsylvania • Washington, D.C. • West Palm Beach, Florida

Representatives:

Australia • Belgium • Canada • Denmark • England • France • Germany • Holland • India • Israel • Italy • Japan • Norway • S. Africa • Sweden • Switzerland

TWX: 910 588-3272 Cable: Endevco

CRITICAL COMPONENTS (continued)

describing the data are stored as a column of seven binary bits which can be arranged into 128 different combinations. By choosing a value for full scale, any number between zero and this full scale is expressed as the nearest fraction (in 127ths) of full scale. The resolution of the data is limited to one part in 127 or 0.79% of full scale. If one of the binary bits is used to describe polarity, the remaining six bits allow a resolution of 1.59% of full scale.

The complement of electronics includes an analog to digital converter, a clock for recording relative time, a signal amplifier for each data channel, and a frame and sequence generator which controls the relationships and sequence of operations. The A to D converter is designed to accept only positive input voltages with a full scale output corresponding to 5 volts on the input. This mode of operation allows disassociation of the data amplitude from its polarity and simplifies the storage of data which is periodically sampled. Negative information is processed by generating an identical positive signal for the A to D converter to operate upon.

The heart of the clock, used to record relative time, is a modified Accutron watch movement which produces an electrical pulse every 15 minutes. These pulses are counted by the time memory which resets itself to zero every 96th pulse; i.e., every 24 hours. The time is thereby always available for recording purposes and has an inherent error band of plus 0 minutes, minus 15 minutes.

Signal amplifiers amplify the electrical outputs of transducers to a level compatible with the 5 volt A to D converter input requirement. These amplifiers have differential output stages which always have available not only the normal data signal but its inverted counterpart. Selective circuitry chooses that output which is electrically positive and gates it to following stages. If the normal data were negative, the inverted output would be chosen and a binary bit would be generated on a separate line to indicate the polarity of the original data. In cases where the transducer signal needs conditioning (such as balancing) that too is provided.

The frame and sequence generator links together all the components of the system and provides the format for their operation. Two modes of recording are designed within the same generator. The first is used with transient data such as shock. This mode is initiated when the data level exceeds a preset threshold level and terminated when the data level falls below that threshold. The second mode is used with quasi-static data; i.e., data which changes relatively slowly and can be sampled. This mode is initiated periodically by the clock, the period being limited to some multiple of 15 minutes. In case both modes are initiated simultaneously, an interlock delays the recording of the quasi-static data until the system is cleared of transient information.

SHOCK RECORDING SYSTEM

The recorder accumulates shock data from three accelerometers (which are normally aligned in three orthogonal axes), converts this data to digital form, and records it with an incremental tape recorder. Recorded are (1) peak shock amplitude which has occurred during that period of time a predetermined threshold was exceeded, (2) polarity of the shock pulse, (3) that period of time determined by when the first channel exceeded the threshold until the last channel fell below the threshold, and (4) the relative time the shock occurred. Whenever the threshold shock level is exceeded by one or more channels then the peak amplitude and polarity data from all three channels is recorded.

In actual operation, the user selects a full scale recording level (by switch) between 2 g to 30 g and sets the threshold control which is adjustable from 0.1 to 0.2 of full scale. The threshold level is now established as the product of the threshold control setting and the full scale setting. This allows the user to select threshold levels varying from 0.2 g as a minimum to 6 g as a maximum.

If the amplified incoming data does not exceed the threshold level, the system will continue to idle with little power consumption and no tape consumption. When events occur that cause the amplified incoming data on one or more channels to exceed the threshold, then the following sequence of operations is initiated: (See Figure 1 for block diagram)

1. The threshold detector simultaneously gates the data to temporary storage circuits and starts the frame and sequence generator in the proper mode. The storage circuitry holds the peak voltage and its associated polarity until the transient event has subsided. The frame and sequence generator has an internal timer which starts timing from this point.

Each channel has separate circuitry for temporary storage of amplitude and polarity, and separate circuitry for threshold detection. Any channel may initiate the recording mode but all channels must be below the threshold level to allow termination of the recording operation.

2. As soon as the data from all three channels has fallen below the threshold, the temporary storage circuits are disconnected from the amplifiers and the timer in the sequence generator is stopped. The temporary storage circuits now hold the peak amplitude and polarity of the X, Y and Z channels. The timer holds the time the shock data was above the threshold level.

SHOCK RECORDING SYSTEM (continued)

3. The system gates, in turn, all temporarily stored data to the analog to digital converter and from there to the tape transport where it is permanently stored on tape along with the relative time that the event occurred. When all data has been put on tape, the sequence generator returns the system to idle, prepared for the next shock input.

To prevent loss of data (should a shock occur in the 25 milliseconds required to convert and record on tape the original data) a second temporary storage circuit is available to each channel to be used when the first circuit is busy. The recorder first converts and records the information in the original set of storage circuits then processes the information in the second set of circuits. When all data have been recorded, then the relative time of event is also recorded and the whole system returns to the idle state. The recording format is given below to clarify the details of recording:

- | | |
|---|------------------|
| <ol style="list-style-type: none"> 1. Polarity and amplitude of X 2. Polarity and amplitude of Y 3. Polarity and amplitude of Z 4. Time above threshold | Memory Circuit A |
| <ol style="list-style-type: none"> 5. Polarity and amplitude of X 6. Polarity and amplitude of Y 7. Polarity and amplitude of Z 8. Time above threshold 9. Relative time of event 10. Space | Memory Circuit B |

The basic accuracy and the resolution of the recorded shock data are limited to that consistent with seven digital bits. When polarity is associated with a recorded number, the accuracy and resolution are limited to that consistent with six digital bits.

| <u>Recorded Data</u> | <u>Accuracy and Resolution</u> |
|------------------------|---|
| Shock Amplitude | One part in 63 is Full Scale (Polarity requires seventh bit) |
| Threshold Duration | One part in 127 (One bit represents one millisecond; i.e., 127 ms full scale) |
| Relative Time of Event | Resolution is 15 minutes with record gap to define 24 hour increments |

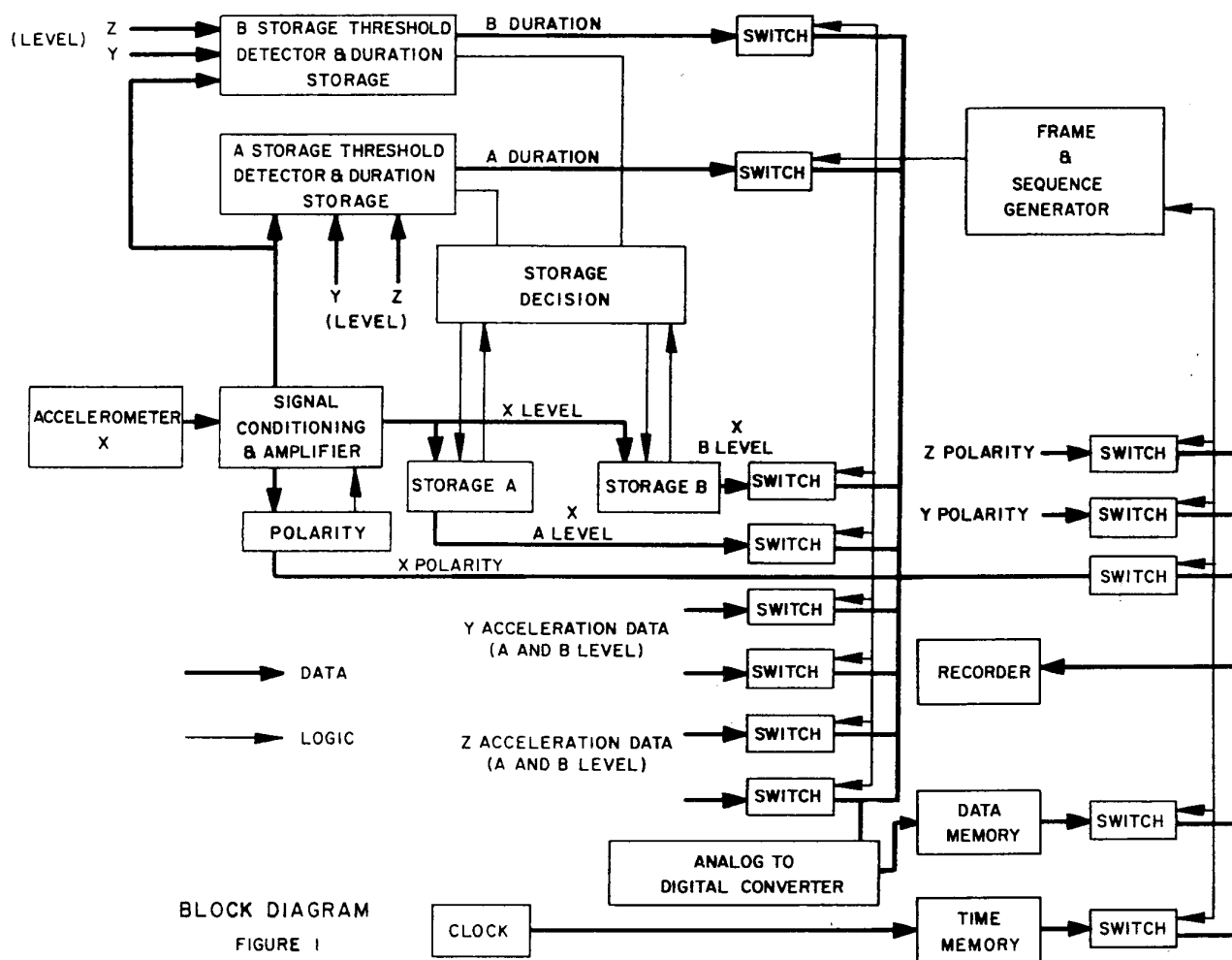

BLOCK DIAGRAM
FIGURE 1

QUASI-STATIC DATA RECORDING SYSTEM

Three channels are available for sampling and recording slowly changing phenomena such as ambient temperature, humidity, or solar radiation. These quasi-static channels have a sampling period of 15 minutes, 30 minutes, or 60 minutes. Seven digital bits represent the amplitude without sign of polarity. The programming is such that, following the clock record command, no action is taken until the system is clear of any shock data. The three channels are recorded in order and the data is concluded with the relative time. This data is easily distinguished from shock information since it uses a different recording format.

The input information is amplified to a level compatible with the 5 volt analog to digital converter input requirement and gated directly to the converter upon command. The sensors providing the input information to the quasi-static channels must be properly phased since only electrically positive signals can be recorded.

QUASI-STATIC DATA RECORDING SYSTEM (continued)

When used to record temperature, for example, electrical zero corresponds to the minimum temperature of interest and full scale positive corresponds to the maximum temperature. This generally requires that the electrical signal be properly biased and amplified. The possible uses of the quasi-static channels are so numerous and diversified that a wide range of amplification, balance, and offset are made available to accommodate a variety of sensors.

RECORDING FORMAT

Recording is accomplished with a cartridge tape loading incremental tape transport. Each tape cartridge contains 300 feet of 1/2 inch tape which is sufficient to record in excess of 100,000 events. The recording mode is NRZ I with an IBM compatible format (minus parity) for easy data reduction and analysis by normal data processing techniques.

PHYSICAL SIZE

The recording system, excluding battery, is 15" x 15" x 9". Electronic functions are on plug-in etched circuit cards and are readily available from the top surface as is the tape cartridge.

POWER REQUIREMENTS

The recording system will operate, unattended, for a period of 16 days from a 12 volt, 120 ampere-hour battery. At the end of this time period, there will be sufficient energy remaining in the battery to fill the recorder to the remainder of its total capacity with information.

SUMMARY

The usefulness of the system is primarily dependent upon two factors. The first and most obvious is the data reduction techniques. The second and less apparent factor is the selection of the threshold level.

If the threshold is set at too low a level in relation to the actual shock data, then the system will tend to mix the shock together with any structure resonances. This will occur by virtue of high probability of at least one of the channels exceeding the threshold and overlapping other channels. The best setting is one which will allow recording of the first pulse and the first few cycles of ringing of the critical acceleration level of interest. At this threshold level there is sufficient data to reconstruct both the basic form of the information on the most active channel and the peak acceleration as seen by the other channels.

SUMMARY (continued)

The nature of the reconstructed data is as follows:

1. Amplitude and polarity of most active channel.
2. Time of most active channel above threshold; this leads to an approximation of the period of the acceleration pulse.
3. Data equivalent to Items 1 and 2 for the first few cycles of ringing of the most active channel; this leads to an approximation of the structure damping.
4. Amplitudes and polarities of the least active channels from which can be deduced information concerning coupling between channels.

Figures 2 and 3 are provided at the end of the text to allow comparison of the input waveform with the reconstructed waveform. No sophisticated data analysis techniques were used in these simple examples and the only assumption made was the half sine form is a reasonable approximation to those portions of the waveform where the amplitude is known.

Although the finer details are lost, properly selected thresholds in conjunction with standard data reduction techniques result in significant information concerning both the basic form and the total energy of the shock pulse.

TRANSIENT PULSE RECONSTRUCTION
HALF SINE

INPUT

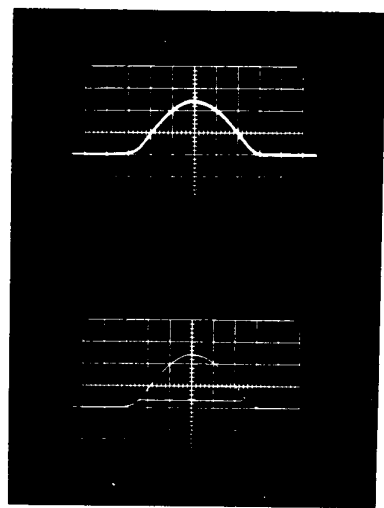

PULSE FORM

PULSE FORM WITH SUPERIMPOSED
THRESHOLD GATE.

← TIME

SCALE X AXIS 1 MILLISECOND PER CENTIMETER
Y AXIS 2 VOLTS PER CENTIMETER

| | <u>RECORDED DATA</u> | <u>REDUCED DATA</u> |
|----------------|----------------------|---|
| PEAK AMPLITUDE | +61 | $\frac{+61}{63} \times 5 = +4.84$ VOLT PEAK |
| PULSE WIDTH | 5 | 5 MILLISECONDS |

DATA RECORDED WITH FULL SCALE = 5.0 VOLTS
THRESHOLD = 0.7 VOLTS (.14 FS)

RECONSTRUCTED WAVE FORM

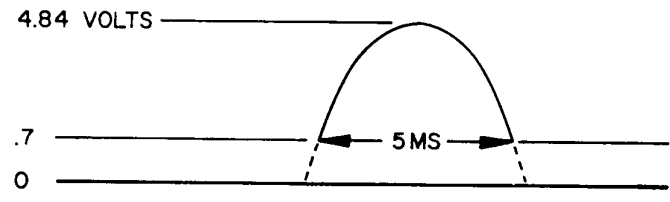
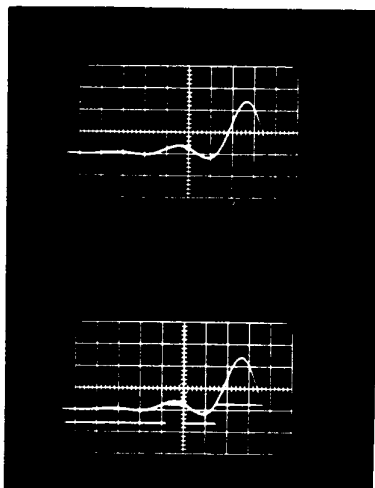

FIGURE 2

TRANSIENT PULSE RECONSTRUCTION

INPUT



PULSE FORM

PULSE FORM WITH SUPERIMPOSED THRESHOLD GATE.

← TIME

SCALE X AXIS 20 MILLISECONDS PER CENTIMETER
 Y AXIS 2 VOLTS PER CENTIMETER

| | <u>RECORDED DATA</u> | <u>REDUCED DATA</u> |
|---------------------|----------------------|---------------------|
| 1st. PEAK AMPLITUDE | +60 | +4.76 VOLTS PEAK |
| 1st. PULSE WIDTH | 41 | 41 MILLISECONDS |
| 2nd. PEAK AMPLITUDE | +10 | +0.79 VOLTS PEAK |
| 2nd. PULSE WIDTH | 21 | 21 MILLISECONDS |

DATA RECORDED WITH FULL SCALE = 5.0 VOLTS
 THRESHOLD = 0.7 VOLTS (.14 FS)

RECONSTRUCTED WAVE FORM

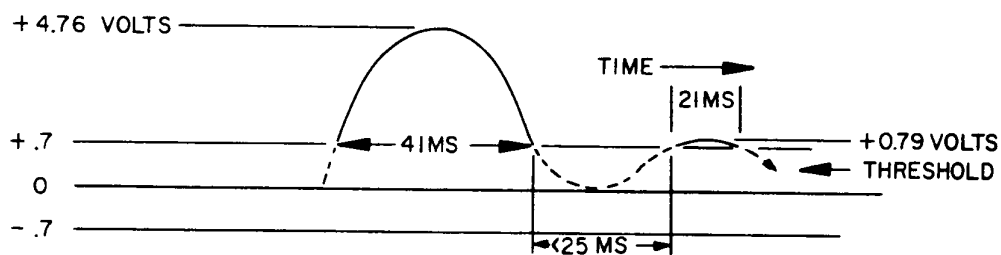

FIGURE 3