

**THERMAL ISOLATION OF ACCELEROMETERS**

By Adam Coghill and Bob Arkell, ENDEVCO® Corporation

Summary

Endevco® Corporation's Accelerometer Thermal Isolator (ATI) significantly extends the operating temperature range of ISOTRON® accelerometers in certain applications. Constructed from a 0.325-inch-thick, lightweight amorphous polymer, the ATI is mounted to an accelerometer by means of a screw and to a test surface with an adhesive.

Application

Endevco manufactures a complete family (ISOTRON®) of piezoelectric accelerometers with internal electronics (IEPE) for low-level vibration measurements. The widespread acceptance of these low-impedance-output devices has spawned increasing interest in their use in applications involving test surfaces with temperatures that exceed these accelerometers' present operating range (-55°C through +125°C).

Thermal isolation is a very cost-effective solution for sensor operation on test surfaces having elevated temperatures. The difficulty of this approach lies in the selection and machining of the isolation material. Care needs to be taken to ensure that such isolation provides sufficient long-term protection while maintaining optimal sensor performance.

Endevco has solved this problem by using a readily machined amorphous polymer. This material is characterized by low thermal conductivity (Figure 1), rigidity at higher temperatures, excellent chemical resistance, high dielectric strength, natural flame resistance, ease of bonding and substantial forming flexibility. Maximum service temperature of this material is +171° C.

**Figure 1**  
**Estimates of Thermal Conductivity for Various Materials**

Figure 1 Estimates of Thermal Conductivity for Various Materials			
Material	Conductivity (W/mK)	Material	Conductivity (W/mK)
Air	0.02	Water	0.6
ATI from Endevco	0.13	Foodstuff	0.2 to 1
Oils	0.2	Wet soil	1.5
Concrete	0.3	Metals	30 to 400

Testing of this material as a thermal isolator was conducted on Endevco's Model 65 ISOTRON® triaxial accelerometer . This titanium, hermetic device has a mass of 5 grams.

The +175°C heat source was a Thermolyne 1900 hot plate. A Fluke thermocouple (Model 80TK) was mounted on the face of the accelerometer furthest away from the heat source.

A 1.63 gram amorphous polymer was used as a Thermal Isolator. It was shaped as a square having a depth of 0.325 inch and a length of 0.500 inch per side. (Figure 2).

*Endevco® Corporation's Accelerometer Thermal Isolator (ATI) significantly extends the operating temperature range.*

*Thermal isolation is a very cost-effective solution.*

**Figure 2**  
**Thermal Isolator Dimensions**

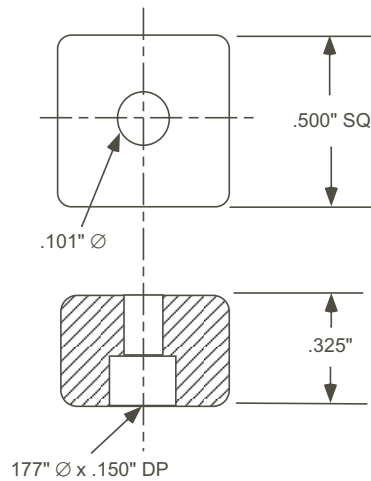

The isolator has a counterbored thru-hole to accommodate an M2.5 cap screw (Figures 2 & 3). The bottom of the model 65 accelerometer has an M2.5 tap to receive this cap screw.

*A wide range of urethane, silicone and acrylic adhesives will provide acceptable adhesion.*

Once the accelerometer is mounted to the thermal isolator with the cap screw, the isolator can be mounted to a mounting surface with a suitable adhesive. A wide range of urethane, silicone and acrylic adhesives will provide acceptable adhesion. It is important to ensure good material contact by using a solvent wipe (Heptane) of the surfaces.

**Figure 3**  
**Thermal Isolators for Accelerometer Models 65 & 63B**



# ENDEVCO TP 317

Generally, we should expect sensors having the greatest mass to demonstrate the most resistance to heat conduction.

Figure 4 indicates that when the Model 65 was placed directly on the pre-heated hot plate at +175 °C, it stabilized at a temperature around +165°C. A decrease in temperature is expected here as all materials do resist heat transfer. Generally, we should expect sensors having the greatest mass to demonstrate the most resistance to heat conduction. As expected, however, the greatest decrease in temperature was associated with the isolator mounted between the Model 65 and the heat source.

**Figure 4**  
**Temperature Measurement Without Isolator, With Isolator, Isolator Only**

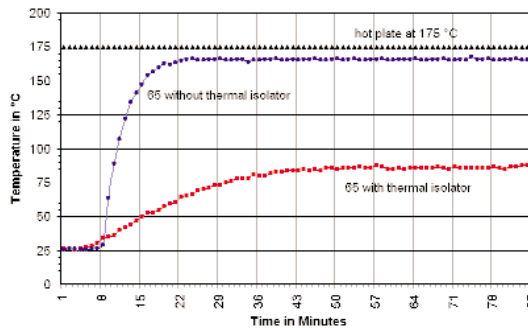

Most important is the observation that the significant decrease in temperature maintains its stability over time. This provides a practical solution to end-users who require "longer-term" solutions for high-temperature sensor exposure. This approach might also be generalized to accelerometers equal to or greater in mass than the Model 65.

**Figure 5**  
**Frequency Response of Model 65 Accelerometer with and without Isolator**

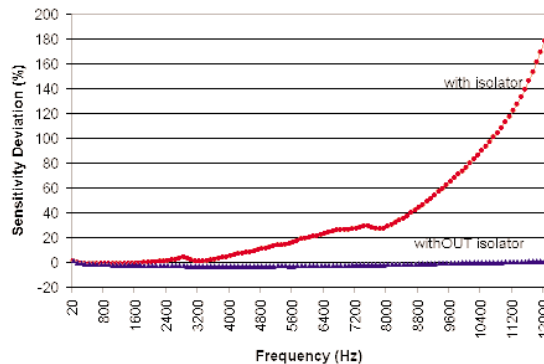

The mounted-resonant frequency of an accelerometer is expected to decrease when material is placed between the mounting surface and the accelerometer itself.

The mounted-resonant frequency of an accelerometer is expected to decrease when material is placed between the mounting surface and the accelerometer itself. When the 65 is used with the thermal isolator, therefore, its linear frequency response is compromised. Figure 5 shows the

## ENDEVCO TP 317

effect the 2988M11-1 thermal isolator has on the model 65's frequency response in the Z-axis. With the isolator, the 65's frequency response is still linear ( $\pm 10\%$ ) out to 4 kHz.

After being fastened to the 65, the isolator was glued to a shaker fixture with cyanoacrylate. For the frequency-response measurement taken without the isolator, the 65 was fastened to a shaker by means of a stud. These measurements were made at room temperature, 72 °F (22 °C).

ISOTRON<sup>®</sup> accelerometers rated for use up to 347 °F (175 °C) are now available. They allow the entire accelerometer to be exposed to an ambient temperature less than or equal to +175 °C. The 175°C version of the 65 is called the "65HT-10."