

## **A high temperature 100 mV/g triaxial accelerometer**

---

Endevco® technical paper 329

# A high temperature 100 mV/g triaxial accelerometer

## Introduction

The need for reliable, high performing and low cost electronics capable of operating at temperatures, higher than 125°C is ever increasing. Zones of high heat found in automobile and aircraft, deep wells for oil and mineral exploration and other geothermal applications, satellites and spacecraft are some examples of applications requiring high-temperature electronics. Due to better performance, smaller size and lower cost, silicon based electronics have become favored for the above applications. Although there is scientific literature describing the possibility of using silicon-based semiconductors in circuits operating at temperatures of up to 250°C, most silicon-based electronics today are rated no higher than 125°C. Designing high-temperature (greater than 125°C) silicon-based electronics continue to be a real challenge.

The Endevco® model 67 high temperature (175°C) piezoelectric (PE) accelerometers with integral electronics (IEPE) are described in this article. Typically IEPE accelerometers incorporate a PE transducer along with a charge or voltage amplifier combined into one package. The PE transducer usually operates at frequencies below its natural resonance frequency. At this frequency range, the PE transducer is essentially a capacitive signal source. As such, a charge amplifier is more suitable, and it is frequently used in IEPE accelerometers. A charge amplifier has the advantages of providing more gain, physical compactness, and independence of the PE transducer's capacitance.

The maximum operating temperature of today's high temperature IEPE accelerometers is restricted by the maximum temperature rating of the integral electronics. Extreme high-temperature acceleration measurements (>250°C) are achieved by a piezoelectric accelerometer without the electronic amplifier. These accelerometers are capable of operating up to 455°C. The PE accelerometer is situated at the hot zone and wired to a remote signal conditioning module located away from the hot area. Connection between the PE accelerometer and the input

of the signal conditioning module is provided by a high-temperature coaxial cable and connectors. A separation of PE accelerometers from a signal conditioner creates an additional connection interface, reduces reliability, increases noise (very high impedance line), decreases dynamic range and is relatively costly.

Another approach is the use of silicon-on-insulator (SOI) or silicon carbide technology for the design of the IEPE accelerometer's electronics. This approach allows reaching temperatures greater than 300°C; however, such accelerometers exhibit inferior performance, are larger in size and more expensive compared with silicon-based electronics sensors. In some applications (e.g., some automotive, aircraft and deep well applications) where the operating temperature is not higher than 175°C, the silicon-based electronics accelerometers are attractive by virtue of their performance, compact size, parts availability, faster turn around and lower cost.

During the last few years not many silicon based high-temperature IEPE accelerometers were designed. Most do not operate beyond 150°C and the sensitivity is no higher than 10 mV/g. This article describes the successful development of a 100 mV/g miniature triaxial accelerometer capable of continuous operation at 175°C.

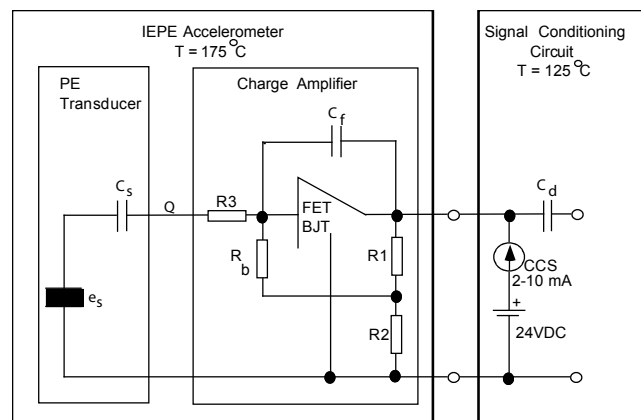

**Figure 1** Configuration of the high-temperature charge amplifier and its connections with the PE transducer and the SCC

## High temp charge amplifier design consideration

Shown in Fig 1 is the basic configuration of the high-temperature charge amplifier and its connections with the PE transducer and signal conditioning circuit (SCC). It converts the charge generated by the piezoelectric transducer into a low impedance voltage output. The charge gain  $G_q$  of the charge amplifier is given by

$$(1) \quad G_q = \frac{1}{C_f}$$

$C_f$  is the feedback capacitance. The SCC provides the constant current source to the charge amplifier and further processes the signal as desired. The high-temperature charge amplifier is composed of two direct coupled stages. The field-effect transistor (FET) input stage provides a high impedance match to the PE transducer while the bipolar transistor (BJT) output stage provides a low impedance output circuit. The FET plays an essential role in high temperature operation. It is selected based on its critical parameters, which make it capable of operating at high temperatures. This is known as the "Zero Temperature Coefficient" (ZTC) FET operating point. Careful circuit design and proper selection of components allow operation at or near the ZTC, optimizing the high temperature circuit performance. A theoretical value of drain current  $I_D = I_{DZ}$  (ZTC drain current) for n-channel FET corresponding to the ZTC bias point is

$$(2) \quad I_{DZ} \approx I_{DSS} \frac{.63}{V_{GS(off)}}$$

$I_{DSS}$  is the saturation drain current, and  $V_{GS(off)}$  is the gate-source cutoff voltage. The ZTC operating point was achieved by the adjustment of resistors  $R_1$  and  $R_2$ . One undesirable significant temperature effect in FET's is its temperature dependence on the gate reverse current (leakage current)  $I_{GSS}$ .  $I_{GSS}$  will increase with temperature causing the ZTC operating point to shift. FETs used in the

design of a charge amplifier have a typical  $I_{GSS}$  value of  $\leq 1$  pA at room temperature. Resistors ( $R_b$ ,  $R_1$  and  $R_2$ ) and capacitor  $C_f$  forms a single pole high pass filter which determines the lower corner  $f_1$  of the frequency range. The -3 dB low frequency corner  $f_1$  equals

$$(3) \quad f_1 = \frac{1}{2\pi R_{in} C_f}$$

$$R_{in} = R_b \frac{R_1 + R_2}{R_2}$$

According to (3), to obtain low  $f_1$  response,  $R_b$  should be high; however, the upper value is restricted due to the leakage current  $I_{GSS}$  of the FET at high temperature.  $R_b$  must therefore be optimized to obtain acceptable low frequency response while maintaining near the ZTC operating point. The upper -3 dB corner  $f_2$  of the frequency range is dictated by resistor  $R_3$  and crystal capacitance  $C_s$  by

$$(4) \quad f_2 = \frac{1}{2\pi R_3 C_s}$$

According to (4) the upper -3 dB corner of the frequency range can only be adjusted by the value of  $R_3$  since the crystal capacitance  $C_s$  is fixed. In some cases where the maximum frequency response is desired,  $R_3$  is reduced to zero. In other cases,  $R_3$  can be optimized to extend the frequency range at the upper frequency as the response approaches the resonance rise.

A circuit based on the above was assembled on a miniature 8 mm ceramic disk substrate. It is very important that any point to point interconnections be executed with compatible metals to avoid inter-metallic diffusion and inter-metallic formation which weakens the bond.

### High temperature PE design consideration

The high temperature aspect of the PE transducer design is less of a problem since PE materials have proven to operate reliably well beyond 175°C. The main challenge is to maximize the charge output of the PE sensing element in a small space. The charge output  $Q$  is given by

$$5) \quad Q = KM$$

$K$  is the piezoelectric crystal charge output coefficient.  $M$  is the seismic mass of the sensing element. The crystal voltage output  $e_s$  is related to the charge output  $Q$  by

$$6) \quad e_s = \frac{Q}{C_s}$$

In order to achieve high charge output, PZT (Lead Zirconate Titanate) crystal was used in the design due to its high charge output coefficient and tungsten alloy metal was used for the seismic mass due to its high weight density.

### Conclusion

A silicon based high temperature IEPE has been designed, built and tested. The high temperature charge amplifier utilizes standard and readily available components assembled on a miniature 8mm ceramic disk substrate. This electronics hybrid circuit was integrated with a high charge output PE transducer that led to the successful development of a low cost, reliable, miniature (14 mm cube), lightweight (12.5 grams) and low noise "100 mV/g triaxial accelerometer" capable of operating from -55°C to +175°C. See following figures



Figure 2 Triaxial IEPE accelerometer (175°C)

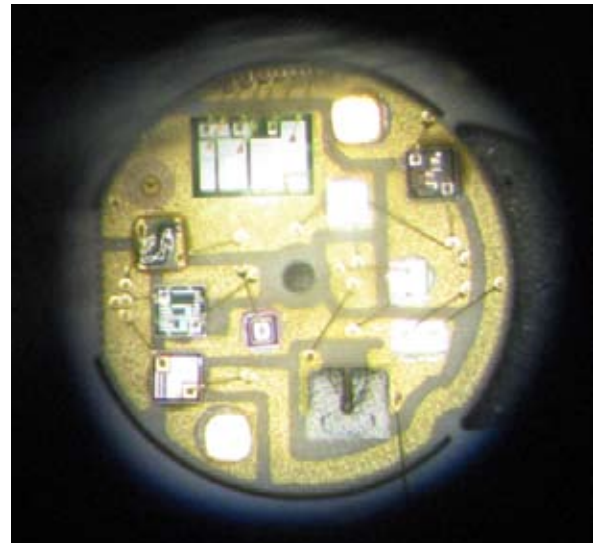
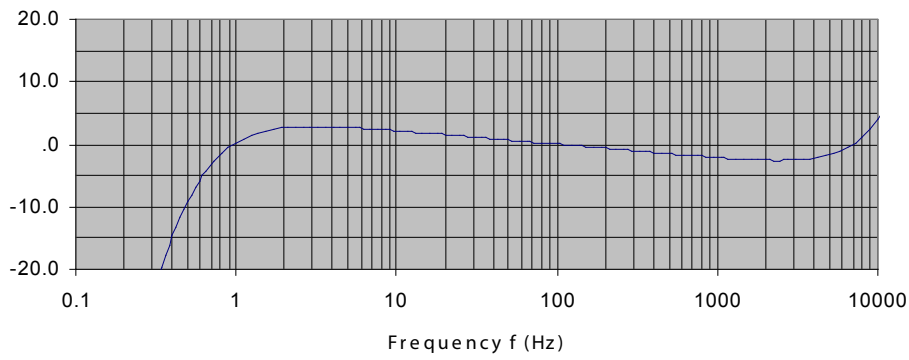
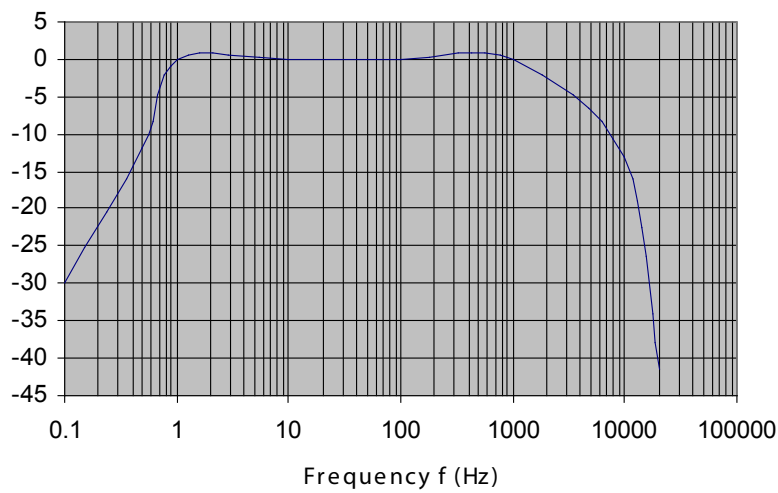

Figure 3 Microphotograph of the hybrid substrate



**Figure 4** Frequency response of the IEPE accelerometer at room temperature



**Figure 5** Frequency response of the charge amplifier at room temperature

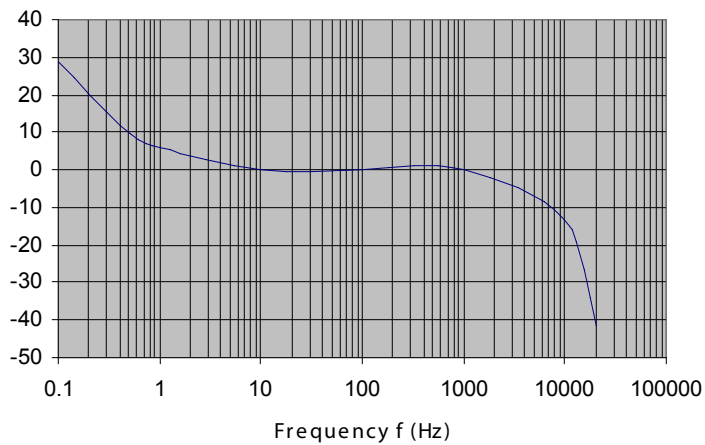

**Figure 6** Frequency response of the charge amplifier at temperature of 175°C

Reference  
 Felix Levinzon, IEEE Sensors Journal Vol 6 No 5 October 2006