



Endevco

Miniature silicon-on-insulator pressure transducer for absolute pressure measurement at 260°C

TP 301

Model 8540 miniature pressure transducer for absolute pressure measurement at 260°C

Abstract

A miniature, silicon-on-insulator absolute pressure transducer designed for continuous high temperature operation up to 260°C, the model 8540, is described. It is intended for engine test cells, wind tunnels and flight testing, as well as for other high temperature applications. It features small size (8.5 gms), excellent dynamic response, high signal output (300 mV), and minimal thermal errors over its entire temperature range (-54°C to 260°C). This transducer utilizes a micro-machined silicon diaphragm with silicon-on-insulator (SOI) construction to eliminate sensor electrical leakage problems at high temperature. The small size and excellent dynamic response of this transducer allows high fidelity measurements to be made in difficult-to-access locations. It is also ruggedized to withstand high shock and vibration environments. Performance data, environmental capabilities, and design features of this pressure transducer will be discussed.

Abbreviations

f_n - natural frequency
SOI - silicon-on-insulator
FSO - full scale output
kHz - Kilohertz
g - Acceleration of earth's gravity
psia - pounds per square inch absolute

Introduction

Accurate pressure measurements can often present a challenge even in fairly benign environments. Attention must be paid to ensure that all pressure seals are leak free, that sensors are warmed up to a stable condition and signal conditioners are adjusted for proper calibration. If dynamic pressures are to be measured, frequency response of the transducer and any plumbing separating it from the desired measurement point must be considered. There must be an adequate signal level for the pressure range of interest. The job can become rapidly more difficult if harsh environments exist where the measurements must be made. Extreme temperatures, shock, vibration, and thermal transients all have potential to either leave their markers in the data or eliminate the data entirely.

The present paper will describe a pressure transducer which is designed to make accurate measurements over a wide temperature range with compensation to 260°C and short term operation to 300°C. It features rugged construction and will operate in high shock or vibration environments with minimal effects on the signal. It has excellent dynamic response with sensor resonances measured in the hundreds of kilohertz. This miniature transducer has an active diaphragm of about one millimeter diameter located very near the end of a 3.9 millimeter cylindrical housing for measurements at small and precise positions with very wide band frequency response. It is intended for static and dynamic pressure measurements in the presence of high temperature and other harsh environments.

Sensor

The pressure sensor in this transducer is a miniature silicon chip which has been anisotropically-etched to form the thin flexing diaphragm. On the diaphragm there are silicon resistors which act as strain gages situated in highly stressed areas to form a Wheatstone bridge circuit. When a voltage excitation is applied to the bridge input and pressure is applied to the diaphragm, the strain gages change resistance in such a way that the bridge output voltage changes proportional to the applied pressure. Figure 1 shows the bridge circuit, with the arrows indicating the direction of resistance changes as pressure is applied. Series thermistors (T1 and T2) are used to compensate pressure sensitivity for temperature changes. As described to this point, the sensor is quite similar to many other silicon-based piezoresistive pressure sensors which are in current use.

This particular sensor, however, is of an unusual, patented design which offers a number of significant advantages over conventional silicon sensors. Essential to this transducer's elevated temperature capability (up to 315°C) is the method of forming the piezoresistive strain gages. Commonly, the strain gages are patterned into a silicon diaphragm by positively doping only those areas which are desired to form the strain gages. The remainder of the diaphragm is negatively doped and a

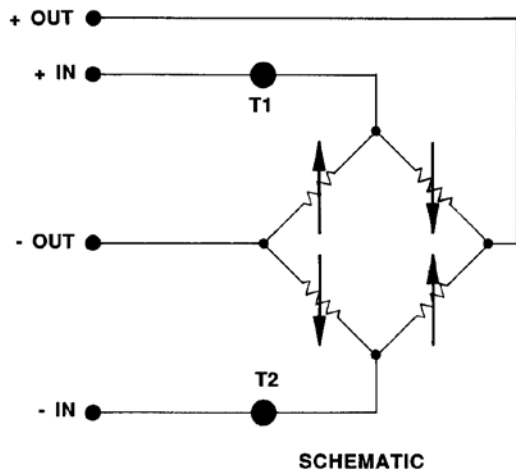

Figure 1.

p-n junction (if reverse biased) electrically isolates the gages from the bulk of the diaphragm, even though the entire diaphragm is physically the same single crystal of silicon. However, the p-n junction (diode) leakage is a very strong function of temperature, and because of excessive leakage current, conventional diffused sensors usually exhibit noise and stability problems if operated at much above 140°C. Conventional sensors are simply unusable at the temperatures needed for the present transducers. This sensor is of a silicon-on-insulator (SOI) type. This means that rather than relying on p-n junction isolation of the strain gage circuitry, the gages are attached to a thin insulating layer of silicon dioxide which covers the surface of the diaphragm. As shown in Figure 2 the strain gages are formed of a separate silicon crystal which are both physically and electrically isolated from the diaphragm. The insulating properties of this oxide layer have been demonstrated to be adequate for sensor operation as high as 480°C, giving a

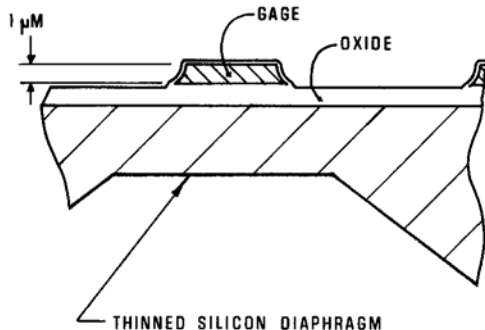

Figure 2.

comfortable margin of safety over the requirements of the present transducer.

The geometry of its sculptured diaphragm and placement of its strain gages also differentiates this sensor from conventional practice. While most silicon pressure sensors use flat diaphragms (either round or rectangular), this one has two mound-like structures situated on the shorter axis of an oval-shaped diaphragm. Narrow channels separate the mounds from each other and form the support walls around the thin diaphragm areas (see Figure 3). With pressure applied the mounds act to form a beam-like stiffener across the diaphragm except for the three thin channels. This causes most of the deflection to occur in the channels. The strain gages are placed right at the three channels where the highest stress on the diaphragm resides. There are several advantages to this sensor structure.

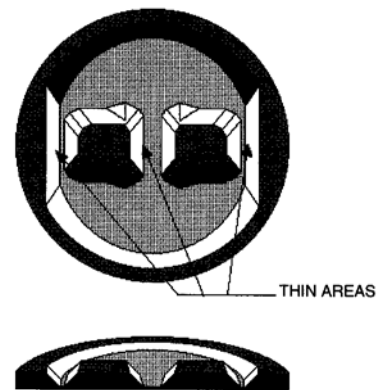

Figure 3.

First is that all the strain gages reside at the maximum stress areas on the diaphragm, maximizing resistance changes. This is not possible with a conventional flat diaphragm, since gages must be placed in both tension and compression areas for an acceptable signal level. The geometry of the sculptured diaphragm can be adjusted for equally high output from both tension and compression gages. The highest stresses are also concentrated in small areas, making failure due to crystal defects less likely. The net result is a substantially higher output signal. With 10 V excitation this transducer has a nominal 300 mV output at full

scale pressure with typical linearity better than 0.25% FSO. There is a comfortable safety margin, since burst pressures are several times the full scale pressure, and measurements to twice full scale with 1% FSO linearity are possible.

This diaphragm is also extremely stiff, which promotes frequency response in two ways: It yields very high resonant frequencies (for example >300 kHz on a 100 psia unit). It also displaces very small volumes of the pressure media when pressure is applied. This minimizes any response degradation caused by flow of the pressure media through tubing, orifices, or other restrictions. The stiffness (and ultra low mass) of the diaphragm also make it very insensitive to shock or vibration inputs which could be present in the measurement location.

One final advantage to the SOI construction is very low sensitivity to light. The output due to a flash bulb at two feet from the sensor is typically 0.4 equivalent psia. This is significant if measurements around combustion gases or other bright light sources are needed.

Overall construction

Since this transducer is for absolute pressure measurements, an evacuated reference cavity is needed for the rear side of the diaphragm. This is accomplished with an etched silicon part which has a cavity and also through holes for routing of aluminum connection wires toward the rear end of the transducer. Attachment and seal of the reference cavity, to the sensor is done with a high temperature sealing glass which yields a very strong bond, and a leak-free hermetic seal for long term stability. The seal is done in a vacuum yielding the 0 psia reference. The stainless steel case has a 3.9 mm diameter x 19 mm long #10-32 UNF-2A threaded portion, with the face of the sensor as near as possible to the end for best frequency response (see Figure 4). There is also a 3/8 hex and a rubber O-ring seal. The overall length is about 29 mm.

Only a paper-thin protective stainless steel screen sits

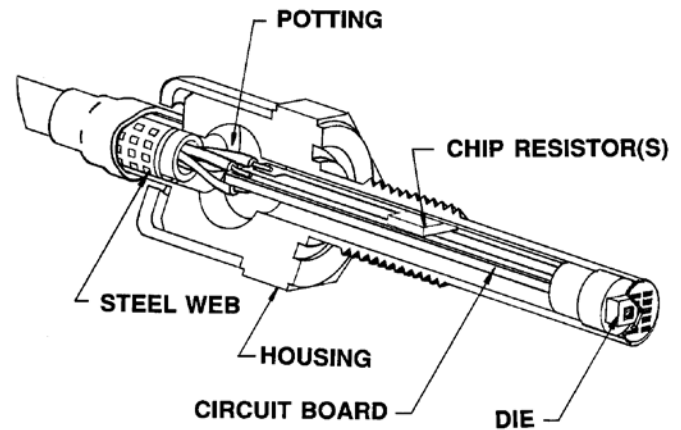

Figure 4

in front of the sensor. The sealed sensor assembly is adhesive-bonded to a larger silicon ring to stress isolate it. That piece is adhesive-bonded to a much larger ceramic cylinder, which is in turn bonded into the stainless steel case. All bonds are made with a specialized high temperature polyimide adhesive. Each support structure has through holes for passage of the sensor wires. The wires are tacked with adhesive inside the holes for support in shock or vibration environments. The sensor wires are bonded ultrasonically to the sensor at one end and to a ceramic circuit board on the other. The circuit board which is used for temperature compensation resistors has thick film gold conductors and both printed and chip resistors. Chip resistors are connected by gold wire bonds. The aluminum sensor wires connect to the board with a tri-metal adaptor chip which avoids an aluminum-gold junction, allowing good high-temperature reliability.

The high operating temperature of the transducer, combined with a requirement to isolate the shield from the transducer housing, created a need to find an improved cable attachment scheme compared to what was currently available. This high temperature requirement necessitates that the jacket material be Teflon®. Although other materials may withstand the temperature, Teflon® was chosen for its toughness and durability.

Potting

A unique cable attachment design, which utilizes

a steel web crimped around the Teflon® jacket, is incorporated into the transducer construction. The web is extruded into the jacket, creating a strong, permanent attachment. The steel web is firmly attached to the transducer housing.

Tests to verify the grip strength of the web to the jacket have shown it to be very strong. One test consisted of suspending a three-pound weight from the cable with the unit in a 295°C oven for 24 hours, after which the jacket could not be pulled away from the grip with 20 pounds of force. Other testing shows the jacket can be completely pulled apart but the web will not come off. In fact to remove the web, it must be filed off and spread apart with pliers, leaving the pressed imprints of the web holes in the jacket.

Another construction difficulty posed by high temperature operation is the electrical connections to the cable. For this, gold jumper wires are used between the circuit board and individual cable wires. The jumpers are ultrasonically bonded to the board and resistance welded to the cable wires. The jumper wires are supported with epoxy for durability.

Performance

Thermal

As described earlier, the unique oxide layer used to electrically isolate the strain gage bridge from the bulk silicon eliminates the high temperature effect of p-n junction leakage. This permits operation at a higher temperature than conventional pressure transducer designs. This feature, coupled with carefully selected materials for construction, as well as an innovative approach to the difficult problem of cable attachment for high temperatures, combine to provide a product that performs accurately and repeatably to 260°C (500°F), with 2-hour excursions to 315°C (600°F) possible, resulting in only minor degradation in performance. Zero Measurand Output (i.e., the imbalance of the wheatstone bridge at 0 psia) is adjusted by selection of internal compensation components, so that the offset does not vary greater than 3% of FSO through the -34°C

to 260°C range, referenced to output at 24°C. Similarly, the sensitivity (response to a pressure input) is adjusted to within 4% of the ambient (24°C) sensitivity from -34°C to 260°C.

Linearity

Non-linearity of transducer output to pressure inputs is typically between 0.2% and 0.4% of full scale output, within the operating pressure range of the instrument.

Noise/resolution

Typical noise level, i.e., output generated within the transducer that is not a product of an externally-generated input, is 5 microvolts rms. Signal inputs that generate greater than 5 microvolts rms can be detected above this noise threshold. With a typical sensitivity of 20 mV/psi for a 15 psia device, this translates to a measurement resolution of .001 psia for that range. Resolution for other ranges vary from this figure proportional to the sensitivity of the range.

Photoflash response

An instrument's response to a transient flash of intense illumination is measured by inducing a "known" level of light intensity as described in I.S.A. Standard ISAS37.10, Para. 6.7, Procedure 1. Ideally, a low response to light is very desirable. This instrument's response to the specified light source as described in the ISA Standard is measured as 0.1 to 0.5 equivalent psi, depending on the pressure range

High dynamic performance

Dynamic performance of the instrument is enhanced by design in two ways: 1) The natural frequency is very high owing to the unique sculptured diaphragm configuration and, 2) The sensing diaphragm, being located nearly flush with the end of the case provides a very minimal "dead area," or volume of space, which can act as a resonator to the measurand media. These design features combine to provide a very high usable frequency response range (for the 50 psi range, this range is approximately 50 kHz, where f_n is 250 kHz). For the 100 psi range, f_n was measured at 357 kHz typical,

providing a usable frequency range from steady state to approximately 70 kHz.

High sensitivity/efficiency

Using the unique sculptured diaphragm results in extraordinary efficiency, providing together a high output and a very wide frequency response capability. The higher output provides a useful signal without amplification. The measurement resolution is also enhanced, due to a high signal-to-noise ratio. Full scale output is typically 300 mV, and ranges from 200 mV to 450 mV.

Acceleration sensitivity

These instruments exhibit a low response to acceleration inputs, whether they are shock, vibration or static acceleration. Typical response to acceleration inputs of the 50 psi range, for example, is .0003 equivalent psi/g.

Shock and vibration

Not only does the instrument exhibit low output response to acceleration inputs, but it survives high levels of shock and vibration without degradation. Units that have been shocked in three perpendicular axes at approximately 10 000 g and then subjected to 300 g pk of sinusoidal vibration in 3 axes, survived without degradation to performance. Additionally, sinusoidal sweeps, in the sensitive axis, from 50–200 Hz at 80 g pk and from 200 Hz to 10 000 Hz at 100 g pk did not cause degradation of performance.

Stability

The product is very stable between data obtained from subsequent performance testing. More significantly, however, after exposure to the severe environments described above, the devices continued to perform within the performance specifications, with the exception of the prolonged 315°C exposure, which produced only a minor degradation of performance.

Conclusion

The model 8540 pressure transducer described here can provide accurate absolute pressure measurement in either static or very high frequency situations, while enduring extreme temperatures and substantial levels of shock or vibration. In addition, it is small enough to fit into very tight quarters such as wind tunnel models. These characteristics allow measurements which might not otherwise be possible.

PRESSURE TRANSDUCER TEST REPORT

MODEL 8540-50

SERIAL # K51C

Range	50	psia
Sensitivity	7.75	mV/psi
Excitation	10.00	Vdc
Zero Pressure Output	-2	mV
Full Scale Output	387	mV
Non-Linearity	.21	%FSO
Hysteresis	.03	%FSO
Non-Repeatability	.1	%FSO
Combined Lin., Hyst., & Rep.*	.24	%FSO
Thermal Zero Shift	.13	%FSO
Zero Shift After 2 × FSO	.01	%2 × FSO
Thermal Sensitivity Shift	1.45	%
Input Resistance	1270	Ω
Output Resistance	923	Ω
Isolation Resistance	>100	MΩ

*RSS

All calibrations are traceable to the National Institute of Standards and Technology and in accordance with MIL-STD-45662.

