



2775AM4 Signal conditioner Instruction manual

IM2775AM4, Revision BC

**ENDEVCO 2775AM4
INSTRUCTION MANUAL**

TABLE OF CONTENTS

<u>SECTION 1: INTRODUCTION</u>	<u>PAGE</u>
1. INTRODUCTION	1-1
2. EQUIPMENT USE	1-2
<u>SECTION 2: CONTROLS AND CONNECTORS</u>	
1. INTRODUCTION	2-1
2. FRONT PANEL-SENSITIVITY SWITCHES	2-2
3. FRONT PANEL-FULL SCALE RANGE	2-3
4. FRONT PANEL-AC ADJ POTENTIOMETER	2-4
5. FRONT PANEL-PERCENT OF FULL SCALE METER	2-4
6. FRONT PANEL-FUNCTION SWITCH	2-4
7. FRONT PANEL-FILTER IN/FILTER OUT SWITCH	2-4
8. FRONT PANEL-CHANNEL/FILTER ID PADS	2-4
9. REAR PANEL-INPUT/OUTPUT CONNECTORS	2-4
10. REAR PANEL-PE/REMOTE SWITCH	2-5
11. REAR PANEL-POWER CONNECTIONS	2-5
12. INTERNAL-POWER LINE INPUT SELECTOR	2-6
13. INTERNAL-FUSE	2-6
14. INTERNAL-SERVO OUTPUT VOLTAGE RANGE SELECTION	2-6
15. INTERNAL-FILTER CONNECTOR	2-6
16. INTERNAL-ADJUSTMENT POTS	2-7
<u>SECTION 3: OPERATING INSTRUCTIONS</u>	
1. UNPACKING AND INSPECTION	3-1
2. INSTALLATION	3-1
3. GROUNDING	3-2
4. CHECKOUT	3-2
5. INITIAL SETUP	3-2
6. OUTPUT CAL	3-3
7. EXTERNAL CAL INPUT	3-4
8. OPERATION	3-4
9. MONITORING ACCELERATION OR OTHER MEASURANDS	3-4
10. AC OUTPUT	3-6

**ENDEVCO 2775AM4
INSTRUCTION MANUAL**

TABLE OF CONTENTS

<u>SECTION 3: OPERATING INSTRUCTIONS (continued)</u>	<u>PAGE</u>
11. OUTPUT CALIBRATION	3-6
12. EXTERNAL CALIBRATION	3-7
13. TEST INPUT	3-7
14. SERVO OUTPUT	3-8
15. DC OUTPUT	3-8
16. PANEL METER	3-8
17. FILTER	3-8
18. USING LONG INPUT CABLES	3-9
19. REMOTE PREAMP	3-9
20. REMOTE INPUT INTERFACE FACTORS	3-9
<u>SECTION 4: THEORY OF OPERATION</u>	
1. CHARGE GENERATORS	4-1
2. CHARGE CONVERSION	4-2
3. LOW FREQUENCY RESPONSE	4-2
4. CIRCUIT DESCRIPTION	4-3
5. CHARGE CONVERTER	4-4
6. PREAMP INPUT CONDITIONER	4-6
7. SENSITIVITY NORMALIZATION STAGE	4-6
8. GAIN STAGE	4-7
9. SERVO AMPLIFIER	4-7
10. AC AND DC OUTPUT STAGE	4-8
11. INTERNAL OSCILLATOR	4-8
12. POWER SUPPLY	4-9
13. SPECIFICATIONS	4-9
<u>SECTION 5: MAINTENANCE AND CALIBRATION</u>	
1. MAINTENANCE	5-1
2. CALIBRATION	5-1
3. INTIAL SETUP	5-2
4. OUTPUT CALIBRATION	5-4

**ENDEVCO 2775AM4
INSTRUCTION MANUAL**

TABLE OF CONTENTS

<u>SECTION 5: MAINTENANCE AND CALIBRATION (continued)</u>	<u>PAGE</u>
5. TEST INPUT	5-5
6. EXTERNAL CALIBRATION INPUT	5-5
7. MAX I OUTPUT	5-6
8. NOISE/DC OFFSET	5-6
9. GAIN ACCURACY	5-7
10. SENSITIVITY SWITCH TEST	5-8
11. FREQUENCY RESPONSE	5-9
12. REMOTE GAIN ACCURACY	5-10
13. REMOTE FREQUENCY RESPONSE	5-10
14. REMOTE NOISE	5-11
15. CONSTANT CURRENT ADJUST	5-12
16. TROUBLESHOOTING	5-12
17. REPAIR	5-13
18. FACTORY SERVICE	5-14
<u>SECTION 6: OPTIONS AND ACCESSORIES</u>	
1. ACCESSORIES INCLUDED	6-1
2. ACCESSORIES AVAILABLE	6-1
3. ADJUSTABLE FILTER	6-1
4. REMOTE CHARGE CONVERTER	6-5
<u>SECTION 7: DRAWINGS AND PARTS LIST</u>	
1. GENERAL	7-1
2. PARTS LIST	7-1
3. DRAWINGS	7-1

**ENDEVCO 2775AM4
INSTRUCTION MANUAL**

LIST OF ILLUSTRATIONS

LIST OF ILLUSTRATIONS

1-1 MODEL 2775AM4 SIGNAL CONDITIONER	1-1
2-1 MODEL 2775AM4 FRONT PANEL	2-1
2-2 SENSITIVITY AND FULL SCALE SELECTION	2-2
2-3 MODEL 2775AM4 REAR PANEL	2-5
2-4 INTERNAL CONTROLS	2-6
3-1 INTERNAL CONTROLS	3-1
3-2 FRONT PANEL CONTROLS	3-3
3-3 OUTCAL DIAGRAM	3-3
3-4 EXTERNAL CALIBRATION DIAGRAM	3-4
3-5 TEST INPUT	3-7
3-6 REMOTE TRANSFER DIAGRAM	3-11
3-7 REMOTE HOOKUP	3-11
3-8 FREQUENCY RESPONSE NOMOGRAPH	3-12
4-1 SIMPLIFIED EQUIVALENT CIRCUIT	4-1
4-2 CHARGE CONVERTER CIRCUIT	4-2
4-3 MODEL 2775AM4 BLOCK DIAGRAM	4-4
5-1 FRONT PANEL CONTROLS	5-2
5-2 REAR PANEL CONTROLS	5-2
5-3 INTERNAL CONTROLS	5-3
5-4 POWER SUPPLY TEST POINTS	5-4
5-5 OUTPUT CALIBRATION	5-5
5-6 TEST INPUT	5-5
5-7 EXTERNAL CALIBRATION	5-6
5-8 NOISE	5-7
5-9 GAIN ACCURACY	5-7
5-10 FREQUENCY RESPONSE	5-9
5-11 REMOTE GAIN	5-10
5-12 REMOTE NOISE	5-11
5-13 CONSTANT CURRENT ADJUSTMENT	5-12

**ENDEVCO 2775AM4
INSTRUCTION MANUAL**

LIST OF ILLUSTRATIONS

<u>LIST OF ILLUSTRATIONS (continued)</u>	<u>PAGE</u>
6-1 PROGRAMMING JUMPER SELECTION	6-2
6-2 CUSTOMIZED CUT-OFF FREQUENCY RESISTOR POSITIONS	6-2
6-3 HIGH PASS FILTER RESISTOR SELECTION CHART	6-4
6-4 LOW PASS FILTER RESISTOR SELECTION CHART	6-5
6-5 2771A DIMENSIONS	6-6
6-6 2771A/2775AM4 TEST SETUP	6-6
6-7 2771A GAIN AND BIAS SETUP	6-8

LIST OF TABLES

2-1 SENSITIVITY AND FULL SCALE RANGE SELECTION	2-2
2-2 CALCULATION OF mV/g VALUES AT AC OUTPUT	2-3
4-1 2775AM4 MEMORY MAP	4-5
4-2 VOLTAGE AMPLIFIER GAIN	4-7
4-3 SERVO AMPLIFIER GAIN	4-8

**ENDEVCO 2775AM4
INSTRUCTION MANUAL**

**SECTION 1:
DESCRIPTION**

1. INTRODUCTION

The ENDEVCO Model 2775AM4 Signal Conditioner is a solid-state instrument designed to condition either the low-level analog acceleration signals from a piezoelectric (PE) transducer or the amplified signals from an Isotron transducer or a remote charge converter. The outputs are AC, DC, and SERVO signals proportional to the acceleration input signal. A back panel switch on the conditioner selects the charge converter stage for direct PE transducer input connection or a constant current signal conditioning stage for accepting the input from a remote preamp device. This flexibility broadens the transducer choices which can be used.

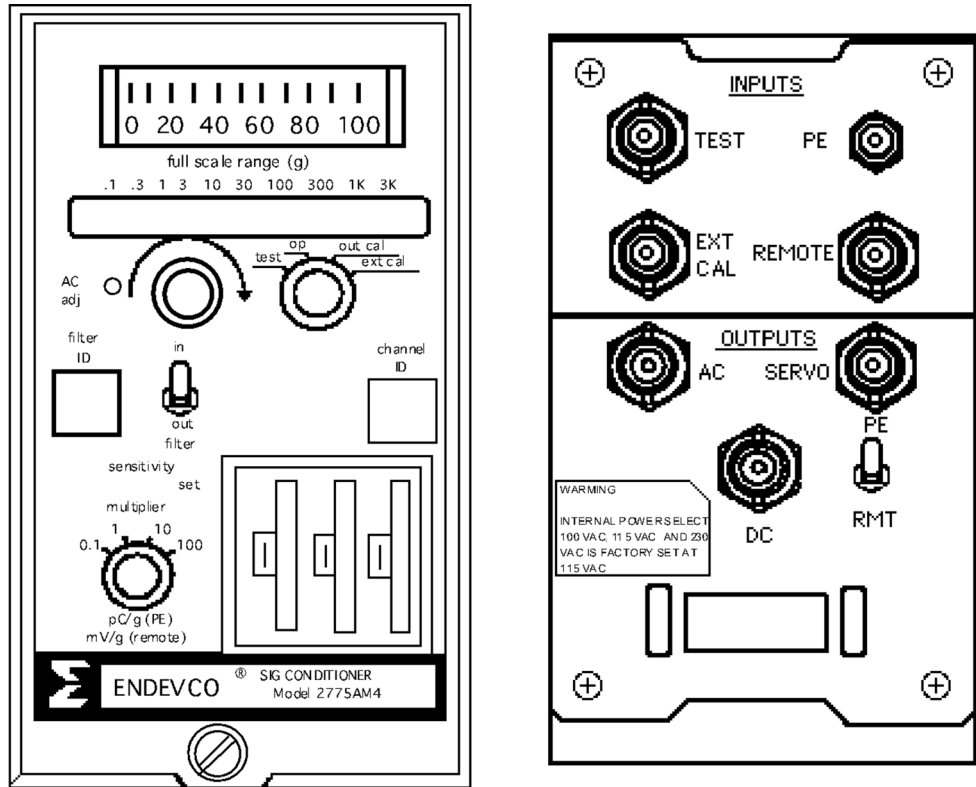

FIGURE 1-1. MODEL 2775AM4 SIGNAL CONDITIONER

When the charge converter stage is switched in, the transducer sensitivity and transducer frequency response are independent of the cable length between the transducer and signal conditioner. Low frequency response of the signal conditioner is also independent of transducer and cable capacitance and depends only on the low frequency response of the charge converter.

For applications where pre-conditioning of the signal is necessary, the Model 2775AM4 can accept the input signal from a remote preamp device. When operating in this mode, the 2775AM4 supplies the constant bias current necessary to operate a compatible remote preamp device such as an Isotron transducer or remote charge converter. This mode of operation is

**ENDEVCO 2775AM4
INSTRUCTION MANUAL**

better suited where low resistance transducers, electrical noise, or long leads from remote locations can affect the acquisition of data.

ENDEVCO 2775AM4 INSTRUCTION MANUAL

Data signals are processed and normalized as three independent outputs. First is an AC output which is front panel adjustable from 1V to 10V pk full scale. The AC output has 85 mA capability sufficient to drive most galvanometer or capacitive loads. A second output is a servo signal scaled for 10mV/g or 100mV/g depending on the placement of an internally inserted jumper clip, factory set to 10mV/g. The third output is a DC signal which provides a linear low impedance output proportional to signal average which is normalized to 10VDC full scale for driving strip chart recorders, etc. The panel meter is driven by the DC output, displaying a linear scale in percent of full scale. All outputs are buffered and current limited to protect against accidental short circuits.

Each Model 2775AM4 contains four regulated power supplies for signal conditioner operation and for supplying constant current power.

Some of the features included in the design of the Model 2775AM4 Signal Conditioner are summarized as follows:

- A. Wide input sensitivity range: 0.1 to 1099 mV or pC/unit.
- B. Multiplier and thumbwheel switches for fast, simple and exact entry of transducer sensitivity.
- C. Unit gain range of 0.3 to 10,000.
- D. LED pointer shows Full Scale ranges: 0.1, 0.3, 1, 3, 10, 30, 100, 300, 1k, or 3k engineering units.
- E. Provision for input from a piezoelectric transducer or from an Isotron transducer (or remote charge converter or remote preamp).
- F. In-out filter control of an optional Model 35771 selectable filter: high-pass, low pass or bandpass filtration of data signals.
- G. Test input for an external test signal to check the integrity of transducer and signal conditioner operation.
- H. Output calibration oscillator generates a precise full scale signal for calibration of measuring and recording devices.
- I. External calibration input for functional calibration check of the signal conditioner.
- J. Operates from 100-, 115-, or 230-volts, 50-400 Hz.
- K. Single-channel, stand alone, operation or six-channel operation in a Model 4948 19-inch rack adapter.
- L. Buffered outputs current limited for short-circuit protection.
- M. Overrange protection: minimum of 7.5 times full scale input.

**ENDEVCO 2775AM4
INSTRUCTION MANUAL**

- N. Easy maintenance and serviceability by elimination of most alignment potentiometers and use of standard components.

**ENDEVCO 2775AM4
INSTRUCTION MANUAL**

2. EQUIPMENT USE

The controls of the Model 2775AM4 are easy to use. After setting the Model 2775AM4 for the desired operating mode, you need only:

- A. Set the transducer sensitivity.
- B. Set the full scale engineering units.
- C. Place the filter (if any) in or out.

The optional Model 35771 adjustable filter will help to exclude spurious signals from your data. The Model 2771A remote charge converter can be used to reduce noise in hostile environments. Section 6 covers all the optional accessories.

**ENDEVCO 2775AM4
INSTRUCTION MANUAL**

**SECTION 2:
CONTROLS AND CONNECTORS**

1. INTRODUCTION

The Model 2775AM4 front panel has five control switches and one output adjustment pot. The back panel has one input mode switch, four input connectors, and three output connectors. Internally, on the main circuit board, the unit has a input power switch, fuse holder, servo range jumper and a constant current pot.

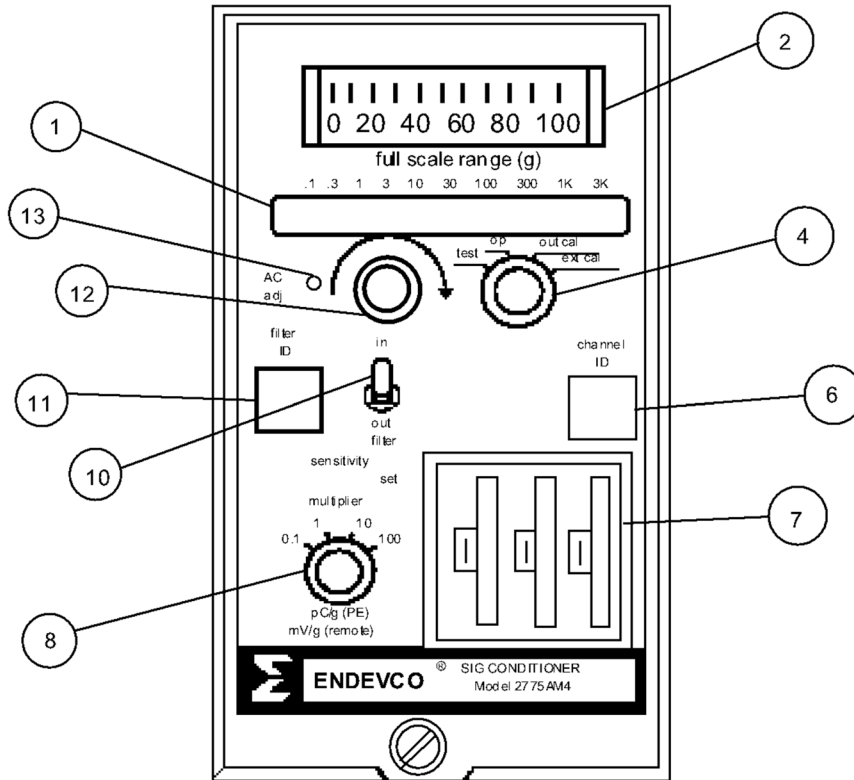

- | | |
|-------------------------------------|------------------------------------|
| 1 Full Scale Range (g) Indicator | 8 Sensitivity multiplier switch |
| 2 Percent of Full Scale Meter | 10 Filter in - out switch |
| 4 Function switch | 11 Filter ID Erasable Labeling Pad |
| 6 Channel ID Erasable Labeling Pad | 12 Full Scale Range switch |
| 7 Sensitivity Set Thumbwheel switch | 13 AC ADJ Potentiometer |

FIGURE 2-1. MODEL 2774AM4 FRONT PANEL

**ENDEVCO 2775AM4
INSTRUCTION MANUAL**

2. FRONT PANEL-SENSITIVITY SWITCHES

Two controls determine the amplifier input sensitivity, and they are a thumbwheel digital switch (Figure 2-1) and a multiplier switch that establishes a range of 0.1 to 1099 pC/g or mV/g sensitivity. Whether the controls represent pC/g or mV/g settings is dependent on the input mode selected; either a charge input from a PE transducer or a remote mV input from an Isotron transducer. The PE-RMT switch and the input connector on the rear panel must both correspond to the input mode of operation.

The sensitivity of the transducer in pC/g or in mV/g is entered as numeral digits into the thumbwheel switches (see Figure 2-2) and the multiplier switch is then placed to establish the decimal point. Be aware that not all of the ten available full scale settings shown on the Full Scale Range Indicator are permitted to be selected with any given sensitivity setting (Table 2-1).

To establish the input sensitivity value for a given transducer or remote preamp device:

- A. Enter the most significant digits of the transducer sensitivity thumbwheel switches. If the input is from a remote charge converter or integral electronics transducer, enter the transfer value.
- B. Use the MULTIPLIER switch to establish the decimal point corresponding to the transducer sensitivity or the transfer value.

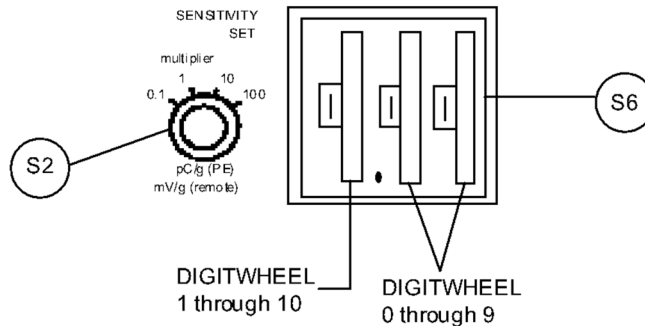

FIGURE 2-2. SENSITIVITY AND FULL SCALE SELECTION

Sensitivity Multiplier	Sensitivity Ranges	Selectable Full Scale Ranges
0.1	.100 to 1.099	10, 30, 100, 300, 1k, 3k
1	1.00 to 10.99	1, 3, 10, 30, 100, 300,
10	10.0 to 109.9	0.1, 0.3, 1, 3, 10, 30
100	100 to 1099	0.1, 0.3, 1, 3

TABLE 2-1: SENSITIVITY AND FULL SCALE RANGE SELECTION

**ENDEVCO 2775AM4
INSTRUCTION MANUAL**

3. FRONT PANEL -FULL SCALE RANGE (g) INDICATOR

The FULL SCALE RANGE (g) indicator has ten full scale ranges that it can indicate: 0.1, 0.3, 1, 3, 10, 30, 100, 300, 1K, or 3K. An LED Lamp lights up to indicate the full scale range selected by the Full Scale Range switch.

NOTE: The full scale ranges, which are permitted to be displayed, depends directly on the input sensitivity selected on the SENSITIVITY SET and MULTIPLIER switches. When you rotate the full Scale Range switch (clockwise or counterclockwise) you will see that not every corresponding LED lamp lights up for each full scale demarcation; only those that indicate permissible gain ranges allowed by the automatic gain scaling capability of the amplifier light up. (Refer to Table 2-1).

The full scale ranges are normally expressed in peak units. In some instances for convenience, the ranges may be expressed in rms units.

NOTE: When using rms units, the rms level (0.707 x V pk) should not exceed the AC output V pk established by the AC ADJ potentiometer (see Figure 2-1.) (The adjustable range for the AC ADJ is 1 to 10 V pk.) Note that the transducer sensitivity expressed in pC/g does not influence the selection of rms or peak readout since the expressed value is a ratio:

$$\frac{\text{pC}}{\text{g}} = \frac{\text{pC pk}}{\text{g pk}} = \frac{\text{pC rms}}{\text{g rms}}$$

The calculated values for millivolts per g (mV/g) at AC OUTPUT with a 10V pk Full Scale (F.S.) setting are shown in Table 2-2. However, for any setting of the AC ADJ potentiometer, the mV/g at the AC OUTPUT can be determined for any full scale as follows:

$$\text{Millivolts Per g} = \frac{\text{Full Scale Voltage (Set by AC ADJ in millivolts)}}{\text{Full Scale Range Selected}}$$

For example, assume AC ADJ is adjusted for 6 V full scale (6000 millivolts) and the Full Scale Range (g) Selector is set for 3 g F.S., this calculates to:

$$\text{Millivolts Per g} = \frac{6000 \text{ mV}}{3 \text{ g}} = 2000 \text{ mV/g}$$

**ENDEVCO 2775AM4
INSTRUCTION MANUAL**

F.S. Volts at AC out via AC ADJ	Full Scale g Ranges									
	0.1	0.3	1	3	10	30	100	300	1K	3K
10V	100V	30.3V	10V	3.33V	1.0V	333mV	100mV	33.3m	10mV	3.3mV
5V	50V	16.6V	5V	1.66V	500mV	166mV	50mV	16.6mV	5mV	1.6mV
3V	30V	10.0V	3V	1.0V	300mV	100mV	30mV	10.0mV	3mV	1.0mV
1V	10V	3.33V	1V	333mV	100mV	33mV	10mV	3.33mV	1mV	0.3mV

TABLE 2-2. CALCULATION OF mV/g VALUES AT AC OUTPUT

**ENDEVCO 2775AM4
INSTRUCTION MANUAL**

4. FRONT PANEL -AC ADJ POTENTIOMETER

The AC ADJ potentiometer (Figure 2-1 and Table 2-2) is used to adjust the AC full scale output voltage within a 1.0V to 10V range to meet user requirements. The voltage is set at the factory for a 10 V pk full scale output unless otherwise specified by the user at the time of delivery.

5. FRONT PANEL -PERCENT OF FULL SCALE METER

An analog meter on the front panel (Figure 2-1) displays the measurand as a percentage of full scale, 0% to 100%.

6. FRONT PANEL -FUNCTION SWITCH

The TEST/OPERATE/OUTCAL/EXTCAL selector switch (Figure 2-1) selects the operating mode. The OP (operate) position is selected for normal on-line test operation.

NOTE: Two light emitting diodes (LED's), separated RANGE display, will light up whenever the mode selector switch is placed at a position other than at OPERATE.

When the TEST position is selected, an external signal may be injected through the rear panel TEST connector to the piezoelectric transducer input shielding. This permits testing of the transducer to signal conditioner connection.

When the OUT CAL (output calibration) position is selected, an internal full scale signal is applied to the AC and DC output stages in order to generate a output voltage for calibration of connected measuring or recording instruments. The SERVO output is not affected by the OUT CAL mode.

When the EXT CAL (external calibration) position is selected, the EXT CAL input is connected to the charge converter input through an internal 1000 pf $\pm 0.5\%$ capacitor to convert the mV input to pC charge input.

NOTE: When EXT CAL is not in use the BNC connector should have a shorting cap or remain connected to a low impedance source to reduce possible pick-up of noise.

7. FRONT PANEL-FILTER IN/FILTER OUT SWITCH

The FILTER IN/FILTER OUT switch (Figure 2-1), when placed at FILTER IN, allows processing of the incoming signal through an optional Model 35771 internally installed filter. The unit is shipped from the factory with a jumper connector in place so the filter switch will not affect the data unless the jumper is removed or the filter is installed. See Section 6 for Model 35771 filter option specs.

8. FRONT PANEL-CHANNEL/FILTER ID PADS

Two labeling pads FILTER ID and CHANNEL ID (Figure 2-1) on the front panel permit the user to pencil in the type of filter, if installed, and the channel ID number.

9. REAR PANEL-INPUT/OUTPUT CONNECTORS

**ENDEVCO 2775AM4
INSTRUCTION MANUAL**

The PE input receptacle is a miniature coaxial 10-32 thread type. All other input and output receptacles REMOTE, TEST, EXT CAL, AC, DC and Servo are BNC Type UG-1094/U or equivalent.

**ENDEVCO 2775AM4
INSTRUCTION MANUAL**

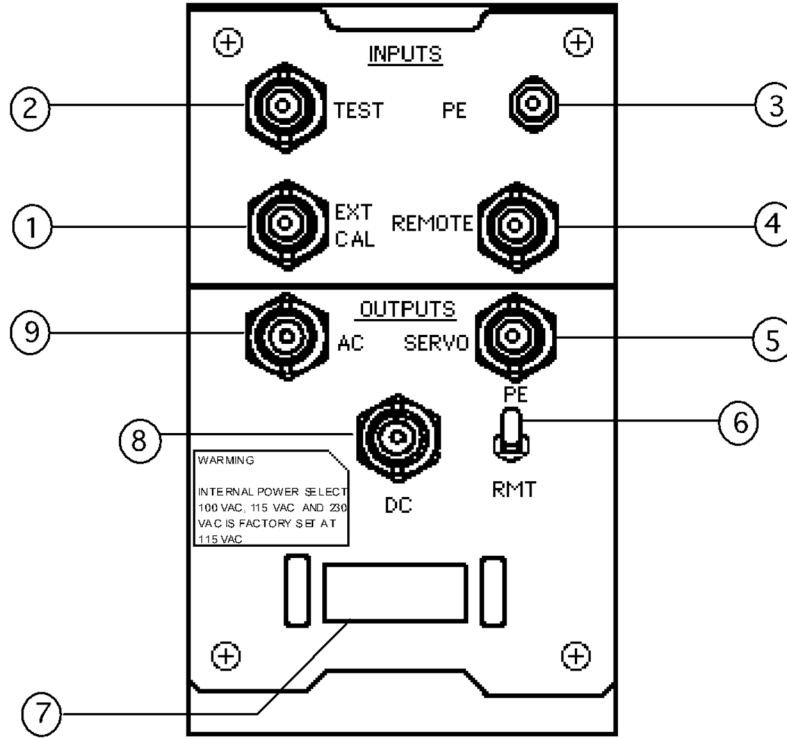

- | | |
|---------------------------|----------------------------|
| 1 EXT CAL INPUT Connector | 6 PE-REMOTE Switch |
| 2 TEST INPUT Connector | 7 AC INPUT POWER Connector |
| 3 PE INPUT Connector | 8 DC OUTPUT Connector |
| 4 REMOTE INPUT Connector | 9 AC OUTPUT Connector |
| 5 SERVO OUTPUT Connector | |

FIGURE 2-3. MODEL 2775AM4 REAR PANEL

10. REAR PANEL-PE/REMOTE SWITCH

The PE/REMOTE Switch determines the mode of operation for the signal conditioner: PE for direct connection to a piezoelectric transducer and RMT for connection to an Isotron transducer or remote charge converter. The corresponding PE input or REMOTE input connector must be used for proper operation.

11. REAR PANEL-POWER CONNECTIONS

The power connector is a 3-prong Cinch P-303. The third wire of the power connector is connected to chassis ground.

NOTE: The 2775AM4 signal ground is delivered from the factory insulated from chassis ground. However, the customer has an option to connect GND (output ground) to chassis ground by soldering a jumper across circuit pads E4 and E5 on the signal conditioner circuit board (See

**ENDEVCO 2775AM4
INSTRUCTION MANUAL**

Figure 2-4). Output ground and chassis ground are normally connected through external test equipment or recording devices third wire ground.

**ENDEVCO 2775AM4
INSTRUCTION MANUAL**

When the signal conditioner is installed in the Model 4948 Adapter, the power connector mates with a receptacle on the inside rear of the Model 4948. The adapter frame and the signal conditioner chassis are grounded by the third wire from the power source.

12. INTERNAL-POWER LINE INPUT SELECTOR

The Power Line Input Selector switch (Figure 2-4) configures the Model 2775AM4 to operate from 50 to 400 Hz power at one of the following voltage ranges:

Switch Position	VOLTAGE RANGE		
POS 1 100 V	90	-	110 V rms
POS 2 115 V	105	-	125 V rms
POS 3 230 V	210	-	250 V rms

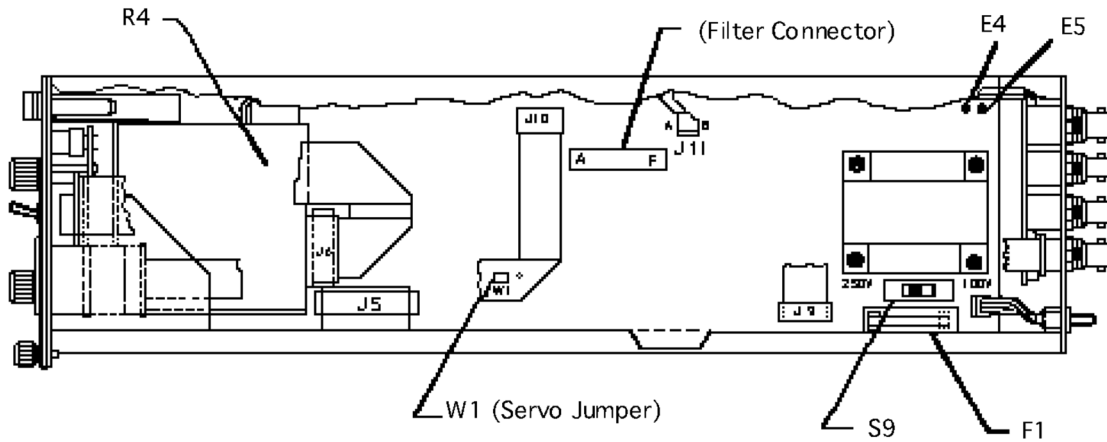

FIGURE 2-4: INTERNAL CONTROLS

13. INTERNAL-FUSE

A fuse, Fusetron, 1/4 A, Type MDL 250-volt, Slo-Blo, or equivalent, is connected in series with the power line. The same fuse is used for all power ranges (See Figure 2-4).

14. INTERNAL-SERVO OUTPUT VOLTAGE RANGE SELECTION

Jumper clip W1 is used to select the fixed mV/g ratio for the servo output. It can be set for either 10 mV/g or 100 mV/g by jumpering the appropriate two pins, see Figure 2-4.

NOTE: The factory setting is 10 mV/g.

15. INTERNAL-FILTER CONNECTOR

Connector J15 (Figure 2-4) permits installation of an optionally provided Model 35771 plug-in filter assembly (high-pass, low-pass, or bandpass.) The filter assembly is held in place by a captive screw. (Refer to Section 6 for the Model 35771 specifications.)

**ENDEVCO 2775AM4
INSTRUCTION MANUAL**

The FILTER IN/FILTER OUT front panel switch provides for user control of the filter. Connector pins are identified as follows:

<u>PIN</u>		<u>FUNCTION</u>
A	-	Signal Input
B	-	Signal Output
C	-	Signal and Power Ground
D	-	-15 Vdc
E	-	+15 Vdc
F	-	No Connection

16. INTERNAL-ADJUSTMENT POTS

The constant current adjust pot, R4, adjusts the constant current level at the REMOTE input connector. The adjustment range is <0.5mA to >20mA. Refer to Section 5.14 for the adjustment procedure.

**ENDEVCO 2775AM4
INSTRUCTION MANUAL**

**SECTION 3:
OPERATING INSTRUCTIONS**

1. UNPACKING AND INSPECTION

The equipment has been thoroughly inspected and tested at the factory, and should be ready for operation when received. The customer, however, should make an inspection to be certain that no damage has occurred during shipment.

Carefully remove the instrument from its packing box. Inspect each item shipped for any sign of damage. Obvious damage should be reported immediately to the carrier.

Inspect each shipping carton and verify that the contents conform to the items of equipment listed on the Packing List. Notify the factory if a discrepancy exists between the Packing List and the contents received.

2. INSTALLATION

The Model 2775AM4 signal conditioner is completely self-contained and may be operated on a bench, or in the Model 4948 Rack Adapter. Up to six units may be mounted in the Model 4948 Rack Adapter and are held in place by a knurled screw located at the bottom of each front panel.

Proper ventilation is required around the instrument when installed in the Model 4948 rack adapter. The top and bottom of the 4948 adapters are open to allow circulation of air. To maintain specification limits and tolerances the air temperature around the 2775AM4 signal conditioners should not be allowed to go higher than +125°F (+52°C) when the instruments are in operation. Rack separation of several inches and or cooling by forced air or convection may be required.

CAUTION: Before applying power make sure the 2775AM4 is correctly set to operate from the local power source to prevent damage to the equipment. DO NOT switch the LINE POWER selector with power applied.

The line power selector is factory set to 110V, if the power available is different, set the LINE POWER selector switch inside the Model 2775AM4 to the correct power line setting.

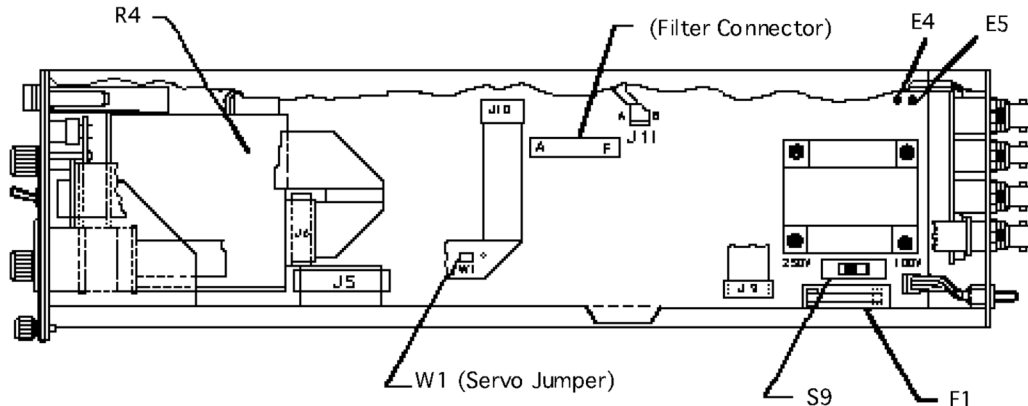

FIGURE 3-1: INTERNAL CONTROLS

**ENDEVCO 2775AM4
INSTRUCTION MANUAL**

Line Power Selector

POS 1 100 V
POS 2 100 V
POS 3 230 V

Power Source

90 to 110 Vac, 50 to 400 Hz
105 to 125 Vac, 50 to 400 Hz
210 to 250 Vac, 50 to 400 Hz

The three-wire power cord for 100- or 115-volt power line operation is terminated in a standard three-prong plug. (For 230-volt operation the plug is not supplied and the ends of the wires are stripped and tinned for installation of an outlet plug from a local supplier.)

3. GROUNDING

The chassis is connected to the third wire ground of the power plug. Insulated guide rails in the Model 4948 rack adapter ensure electrical separation of the amplifier signal grounds from other amplifiers. To prevent pickup of stray electrical noise, it may be required to connect the signal output ground to third wire ground via external equipment or chassis ground. This also may be done by soldering a jumper between E4 and E5 pads on the circuit board (see Figure 3-1).

NOTE: Multiple ground points in any one data channel must be avoided to prevent ground loops.

4. CHECKOUT

The following equipment is required for checkout:

DVM	True RMS Voltmeter 0.1% accuracy or better (Fluke 8050A or equivalent)
Oscilloscope	General Purpose Oscilloscope 10 MHz bandwidth or greater (Tektronix 2213A or equivalent)
Signal Generator	Synthesizer/Function Generator 0.1Hz to 100 KHz (Hewlett Packard 3310A or equivalent)
Frequency Counter	Multi-Counter (Fluke 1900A or equivalent)

5. INITIAL SETUP

On the back panel, set the MODE switch (S5) to PE. On the front panel, from top to bottom, left to right, set the following controls as indicated (Figure 3-2).

ENDEVCO 2775AM4 INSTRUCTION MANUAL

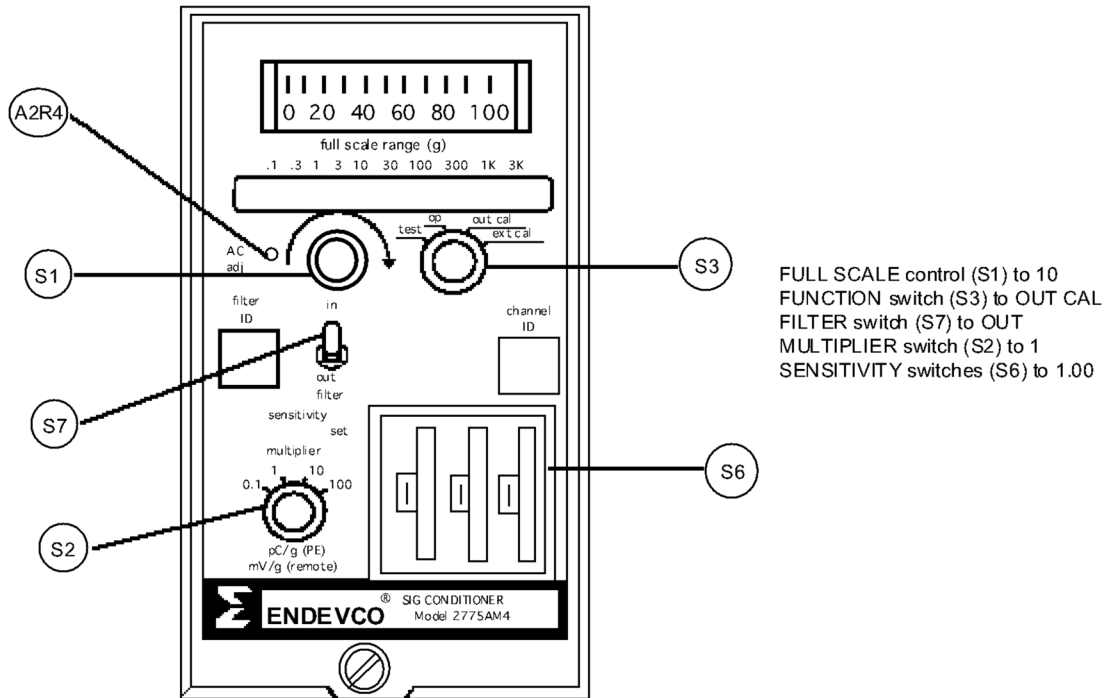

FULL SCALE control (S1) to 10
 FUNCTION switch (S3) to OUT CAL
 FILTER switch (S7) to OUT
 MULTIPLIER switch (S2) to 1
 SENSITIVITY switches (S6) to 1.00

FIGURE 3-2: FRONT PANEL CONTROLS

6. OUTPUT CAL

Set the FUNCTION switch (S3) to OUT CAL. Monitor AC OUTPUT (J12) with a Frequency Counter and an oscilloscope and verify that the internal oscillator sine wave is between 950 and 1050 Hz (Figure 3-2).

Monitor the AC OUTPUT (J12) with a DVM in the rms mode for a full scale $\pm 1\%$ reading. This output should be between 7.00 and 7.14 V rms (10Vpk) which is the factory calibrated setting or should be the user specified full scale level needed for operational use. Refer to Section 5 for AC output adjustment (A2R4).

Monitor DC OUTPUT (J14) with a DVM for a 10VDC ± 150 mV full scale reading.

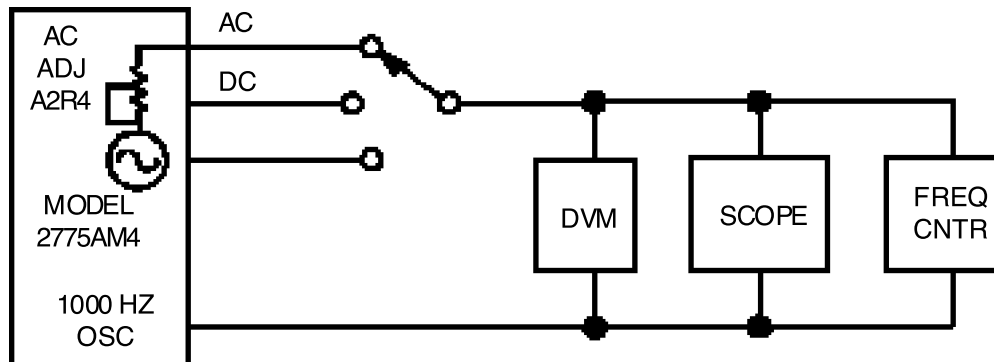

FIGURE 3-3: OUT CAL DIAGRAM

**ENDEVCO 2775AM4
INSTRUCTION MANUAL**

**ENDEVCO 2775AM4
INSTRUCTION MANUAL**

7. EXTERNAL CAL INPUT

Set the FUNCTION switch (S3) to EXT CAL and apply 10mV pk (7.07mV rms) at 1 kHz into EXT CAL INPUT and measure the AC OUTPUT (J12) for a full scale $\pm 3.0\%$ reading. This output should be between 6.86 and 7.28 V rms which is the factory calibrated setting or should the user specified full scale level be needed for operational use.

Set S1 at 100 and the input voltage at 100 mV pk (70.7 mV rms). Measure servo output for 1V pk (0.707 V rms) $\pm 2.0\%$.

NOTE: When external cal is not in use, leave connected to a low impedance source or install a shorting cap to prevent noise pick-up.

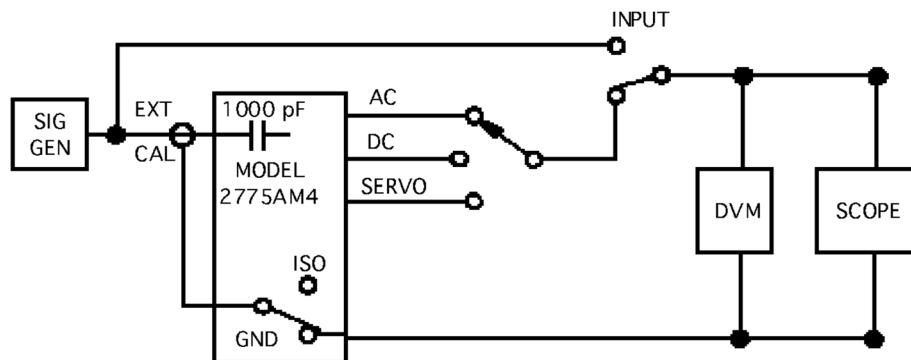

FIGURE 3-4: EXTERNAL CALIBRATION DIAGRAM

8. OPERATION

Before utilizing the signal conditioners, the operator should be thoroughly familiar with the controls and with signal levels available at the output connectors. A complete knowledge of the instrument will ensure that meaningful data is obtained. It is recommended that all of this manual, particularly Sections one, two and the specifications in the data sheet (at the back of this manual) be understood before attempting to make a measurement.

9. MONITORING ACCELERATION OR OTHER MEASURANDS

To prepare the Model 2775AM4 for conditioning the signal from a transducer, the following procedure is recommended:

- A. Establish a desired full scale AC output voltage. This voltage is adjustable from 1 to 10 V pk by means of the AC ADJ potentiometer (See Figure 3-2.) It is normally set at the factory for a full scale output of 10 volts peak unless specified otherwise.
- B. To change the full scale AC output voltage, set the FUNCTION switch to OUT CAL, and adjust AC ADJ potentiometer for the desired full scale output. (Refer to calibration procedure in Section 5.)

**ENDEVCO 2775AM4
INSTRUCTION MANUAL**

- C. From the calibration record card supplied with the transducer, note the charge sensitivity expressed in picocoulombs per g (pC/g).

**ENDEVCO 2775AM4
INSTRUCTION MANUAL**

- D. Adjust the SENSITIVITY SET switches to indicate the transducer sensitivity and set the sensitivity MULTIPLIER to establish the decimal point for the sensitivity determined in Step 2. (Refer to paragraph 2.1).
- E. Set the front panel switches to the following positions:
 - 1. Function switch to OP (operate).
 - 2. Filter switch to IN or OUT.
- F. Connect the input device to the appropriate input on the rear panel: PE INPUT or REMOTE INPUT and place the INPUT MODE switch in the corresponding position.

NOTE: It is recommended to turn off the amplifier before connecting an Isotron accelerometer to prevent damage to the internal electronics.

- G. To minimize the effect of unavoidable ground loops, the accelerometer should be isolated from ground by an insulated mounting stud.
- H. Apply power to the signal conditioner and turn the Full Scale Range control until the desired full scale range is indicated by the LED indicator (See Table 2-1 for the available full scale ranges.) The signal conditioner will be ready for use in less than five minutes; however, it may not meet all specification requirements until it has warmed up for 30 minutes.
- I. Whenever a full-scale output signal for setup calibration of recording instruments is needed, place the operating mode selector switch at the OUT CAL position. The AC and DC output signals will represent peak full scale outputs regardless of the input sensitivity and full scale range settings.

NOTE: When the operating mode selector switch is in OUT CAL, the input signal to the signal conditioner is disconnected.

- J. Return the operating mode selector switch to the OP position.
- K. The Servo output may be selected for 10mV/g or 100mV/g by a jumper clip on the main circuit board. The Servo output is independent of the full scale g range selected. The top cover must be removed to set the servo jumper clip (see Figure 3-1).

NOTE: The top cover is grounded to the chassis by the screws at the top of the signal conditioner. These screws must be tightened in place at all times to ensure proper shielding of the components within the signal conditioner.

NOTE: When the Servo output is used for shaker control, DO NOT CHANGE FULL SCALE RANGES WHILE THE SHAKER IS IN OPERATION. The switching transients may appear on the Servo line causing a change in shaker response resulting in over or under test of articles on the shaker.

- L. The signal conditioner is now ready to accept the signal from the transducer. The number of engineering units (g, lbs, psi, etc.) represented by the output voltage is equal to the voltage divided by the system sensitivity, expressed as follows:

$$\text{Engineering Units} = \frac{\text{AC Peak Volts Out}}{\text{System Sensitivity}} \quad (1)$$

ENDEVCO 2775AM4 INSTRUCTION MANUAL

Where:

$$\text{System Sensitivity} = \frac{\text{Full Scale Output (V pk)}}{\text{Full Scale Range [g pk, lb}_f \text{ pk, etc.]}} \quad (2)$$

$$\frac{\text{volts}}{\text{pk}} = \frac{\text{volts pk}}{\text{g pk}} = \frac{\text{volts rms}}{\text{g rms}} = \frac{\text{volts}}{\text{g}}$$

To solve a typical example of the engineering units represented by the AC output voltage, assume:

1. The Full Scale AC Output is adjusted to 10 V pk (AC ADJ pot.)
2. The Full Scale Range is set for 100 g pk.
3. An 8 V pk signal is present at the AC OUTPUT. Determine the g level represented by the 8 V pk at the AC OUTPUT.

First, using formula (2), calculate for system sensitivity

$$\text{System Sensitivity} = \frac{10 \text{ V pk}}{100 \text{ g pk}} = 0.10 \text{ V/g}$$

Then using the calculated system sensitivity value, the AC OUTPUT reading of 8 V pk, and formula (1),

$$g = \frac{8 \text{ V pk}}{0.10 \text{ V/g pk}} = 80 \text{ g}$$

To express accelerometer sensitivity in pC/m/s^2 multiply sensitivity in pC/g by 9.807. (Precise conversion is $1 \text{ g} = 9.80665 \text{ m/s}^2$)

10. AC OUTPUT

The full scale AC output voltage will depend on the setting of the AC ADJ potentiometer (Figure 3-2), and is adjustable from 1 to 10 volts peak. It is normally set at the factory for 10 volts peak except when specified otherwise. The AC output is capable of delivering up to 85mA pk, which is sufficient to drive most high frequency galvanometers or long cables.

Both input and full scale output should be expressed in peak units. The input measurand may be expressed in rms units by converting from peak units; however, assure that the maximum peak specified is not exceeded by converted rms levels.

The signal at the AC output connector is in phase with the input signal when the internal filter is not used or when the 35771 selectable Filter is installed. However, when low pass or high pass active filters (such as 35257 or 35330 Series) are selected, which were utilized in past signal conditioners, the output signal is inverted with respect to the input (See Section 3-17: Filter). The model 2771A remote charge converter inverts the input signal 180 degrees.

**ENDEVCO 2775AM4
INSTRUCTION MANUAL**

11. OUTPUT CALIBRATION

Placing of the operating mode selector switch at OUT CAL disconnects the signal conditioner input and connects an internal sinusoidal oscillator to one of the intermediate output stages. The signal is processed and its amplitude represents the full scale peak of the measurand regardless of the position of the input sensitivity switches and Full Scale Range selector switch. Recording instruments connected to the AC and DC outputs can be calibrated for peak full scale readings.

12. EXTERNAL CALIBRATION

When you need to check the operating condition of the Model 2775AM4, the EXTERNAL CAL input can be used. Calculate the oscillator V pk signal value needed for a desired peak AC full scale output. The AC OUTPUT will be 10 V pk if the factory adjusted voltage is unchanged or will be whatever user selected voltage has been set by the AC ADJ pot. To obtain full scale output, the voltage input in mV should be:

$$V_{in} [mV] = F.S. \times S$$

Where: F.S. is the full scale range and S is the sensitivity setting (This is the input voltage for a peak full scale output.)

Verify that the amplifier output is within 2.0% of full scale for the expected AC, DC or Servo Output.

13. TEST INPUT

An external sine wave oscillator can be connected to the TEST INPUT connector to insert a signal in series between the transducer and input of the charge amplifier. The signal is transformer coupled and is applied to the PE cable shielding when the mode select or switch is in the TEST position (See Figure 4-3 in Section 4). The test input can be any voltage which will give a convenient reading at the output. The test frequency must be between 100 and 10000 Hz. Figure 3-5 shows the Test Input mode.

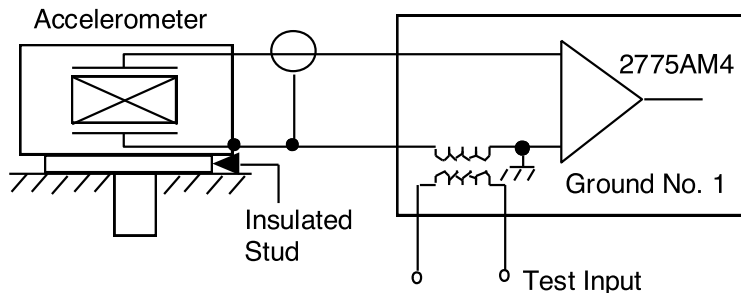

FIGURE 3-5: TEST INPUT

This test signal is normally used to verify that the transducer and its cable are properly connected. A predictable output is produced when the test signal amplitude is adjusted to the value calculated as follows:

$$E_t = \frac{GS}{\text{volts peak}}$$

**ENDEVCO 2775AM4
INSTRUCTION MANUAL**

$C_p + C_c$

ENDEVCO 2775AM4 INSTRUCTION MANUAL

Where: E_t = Test Signal Voltage
 G = peak amplitude of simulated signal; g, psi, lbs, etc.
 S = charge sensitivity of transducer, pC/g, pC/psi, etc.
 C_p = capacitance of transducer, pF
 C_c = capacitance of input cable, pF

If G is equal to the setting of the Full Scale Range switch, the output voltage will be at approximately calibrated full scale.

If the cable and signal conditioner are connected properly, the charge "seen" by the charge amplifier will be:

$$Q = E_t (C_p + C_c) \text{ pC pk}$$

If the transducer is disconnected, the input charge will be: $Q^1 = E_t (C_c)$ and the output voltage will be reduced from the anticipated magnitude by a factor of $C_c / (C_p + C_c)$.

Because the Test Input signal is transformer coupled, any number of Test Input terminals may be connected to one signal generator with a common ground. The Test Input feature cannot be used in the remote mode of operation.

14. SERVO OUTPUT

The Model 2775AM4 provides a servo signal voltage proportional to the input signal scaled for either 10 mV/g or 100 mV/g. (The mV/g setting is internally selected by a moveable jumper clip. It is set at the factory at 10 mV/g.)

The output is an unfiltered (broadband) signal in phase with the input signal. Specified maximum signal linearity is 12 V pk. Assuming that the servo output is set for 10 mV/g, the maximum g level for an undistorted servo signal is 1200 g regardless of sensitivity or full scale settings. (For a 100 mV/g servo output setting, the maximum is 120 g.)

15. DC OUTPUT

The Model 2775AM4 provides a DC voltage at the DC output connector proportional to the average value scaled to pk of the input signal. With a sinusoidal full scale input signal, the full scale DC output is +10 volts peak. Maximum output current is 3.0 mA.

16. PANEL METER

The meter obtains its signal from the AC-DC converter and, therefore, responds to the average magnitude of the input signal scaled to pk. It indicates percentage of full scale and is most accurate for sinusoidal input signals.

ENDEVCO 2775AM4 INSTRUCTION MANUAL

17. FILTER

The FILTER IN/FILTER OUT front panel switch permits for user control of the internal filter. An optionally provided Model 35771 selectable filter card is adjustable to function as a low-pass, high-pass or bandpass filter. Refer to Section 6 for the available cut-off frequencies or for the calculation of customized cut-off frequencies.

Two earlier model series of filters (which may exist in your inventory) can be used in the 2775AM4 Signal Conditioner; however, the inversion actor of the active high and low-pass filters must be taken into consideration. The Model 35257 is a series of low pass filters; the Model 35330 is a series of high pass filters. Both of these series are active two-pole Butterworth designs providing 12 dB per octave rolloff. The AC output signal is inverted with respect to the input when these filters are selected.

18. USING LONG INPUT CABLES

The maximum allowable source capacitance, to meet all specifications, is 30 000 pF. Source capacitance includes both transducer and input cable capacitance. An input capacitance greater than that specified above will result in increased residual noise and some loss in gain of the amplifier.

19. REMOTE PREAMP

An Isotron transducer or remote charge converter (or remote preamp) may be connected to the Model 2775AM4 with standard coaxial or low impedance, shielded, twisted-pair cable. The cable carries the DC power to the remote preamp device and, at the same time, carries data signals to the Model 2775AM4.

When the PE-RMT INPUT MODE switch is at the remote (RMT) position, the internal Charge Converter circuit is disconnected and replaced with the Preamp Input Conditioner circuit. All features of the Model 2775AM4. Signal Conditioner, except Test Input, and External Cal may be used when operating in the remote mode. No damage will occur if the switch is in the remote (RMT) position without a remote preamp connected to the input.

20. REMOTE INPUT INTERFACE FACTORS

There are four principal factors to be aware of when connecting the remote input. These factors are: (1) the constant current specified for the remote device (preamp) to be connected, (2) the compliance voltage of the constant current source, (3) the specified bias voltage at which the remote device operates, and (4) the high frequency response limitations of the remote device to 2775AM4 coupling system.

CAUTION: Turn the 2775AM4 off before connecting Isotron accelerometers to the remote input. This prevents damage to the internal electronics of the transducer due to capacitance discharge of the cable.

Knowledge of the constant current rating for the remote device is important so as not to exceed its constant current handling capabilities when connected to a current source. (NOTE: The 2775AM4 has an adjustable 0.5 to >20 mA constant current source. Refer to Section 5 for the

**ENDEVCO 2775AM4
INSTRUCTION MANUAL**

Constant Current Adjustment procedure. Do not leave adjusted higher than 20mA to prevent damage to Isotron accelerometers).

ENDEVCO 2775AM4 INSTRUCTION MANUAL

The compliance voltage level and the remote device bias voltage are factors that determine the signal transfer characteristics of the device. Figure 3-6 shows the transfer characteristics of a typical remote preamplifier. In the 2775AM4, the compliance voltage is 25 Vdc, the AC maximum is 20 V pk-pk, and the combined AC and DC components cannot exceed 25 volts.

To illustrate signal transfer, assume we have a representative Isotron accelerometer which operates at a bias level of 10.0 V nominal and can handle up to 20 mA of constant current (See Figure 3-6). Referring to Figure 3-7, one can see that the 10.0 V operating bias level and the 2775AM4 compliance voltage of 25 Vdc allows a 10 V pk-pk AC signal to be transferred without clipping.

High frequency response limitations must also be considered when using long cable to couple a remote device to the 2775AM4. The current that is available to drive a coaxial cable, the peak signal level, and the cable capacitance are all important and interrelated factors that determine frequency response of the coupling system.

Again, let us use our representative Isotron transducer as an example to illustrate frequency response. Assume that the 2775AM4 is adjusted to provide 10 mA of constant current. Of the 10 mA, assume 1 mA is needed for device operation without distortion; therefore, up to 9 mA are available to drive the capacitance load inherent in a cable.

Referring to Figure 3-8, the nomograph shows the frequency response for a given cable capacitance as a function of peak AC voltage and the available drive current. The relationship of volts peak to available current is: V/mA. Using the 10 Vpk that the 2775AM4 can handle, and dividing this by the 9 mA available drive current gives us 1.1 volt per mA. Using the nomograph, Figure 3-8, one can determine the approximate maximum frequency that can be transmitted for any given cable capacitance. (i.e. 14 kHz for 10,000 pF cable capacitance.)

For instance, assume that your coaxial cable in this case is 100 feet long. Thus, you have 3,200 pF of capacitance (coaxial cable capacitance is 32 pF/ft typical.) From the nomograph, this capacitance and the 1.1 volt per mA value yields a maximum frequency response of approximately 49 kHz. This cable length, therefore, is satisfactory for the 2775AM4 REMOTE input. The frequency response with a remote input is dependent on the Full Scale and sensitivity multiplier settings and can be as high as 70 kHz. (See specifications)

An alternative to using the nomograph is to calculate the frequency response. Generally, the highest frequency that can be transmitted without current limiting is:

$$f_{\max} = \frac{I}{2 \text{ pVC}} \quad (1)$$

Where I is maximum available drive current in amperes, V is peak sine wave signal in volts, and C is capacitance in picofarads.

A coupling system with longer cable lengths can be used for signal transfer, but only if AC sine wave signals of low amplitude are transmitted. This is because a larger capacitive load (longer cable) can be driven by lower amplitude signals. This relationship can be seen from equation (1).

ENDEVCO 2775AM4 INSTRUCTION MANUAL

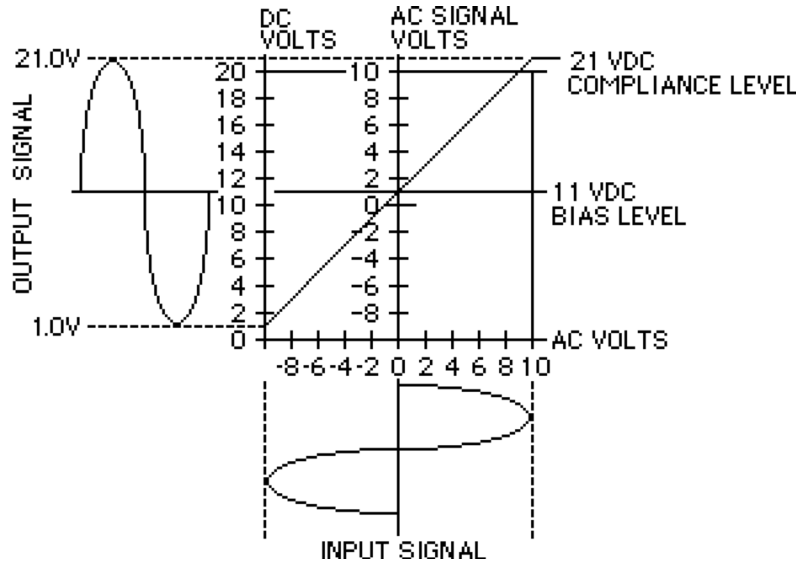

FIGURE 3-6: REMOTE TRANSFER DIAGRAM

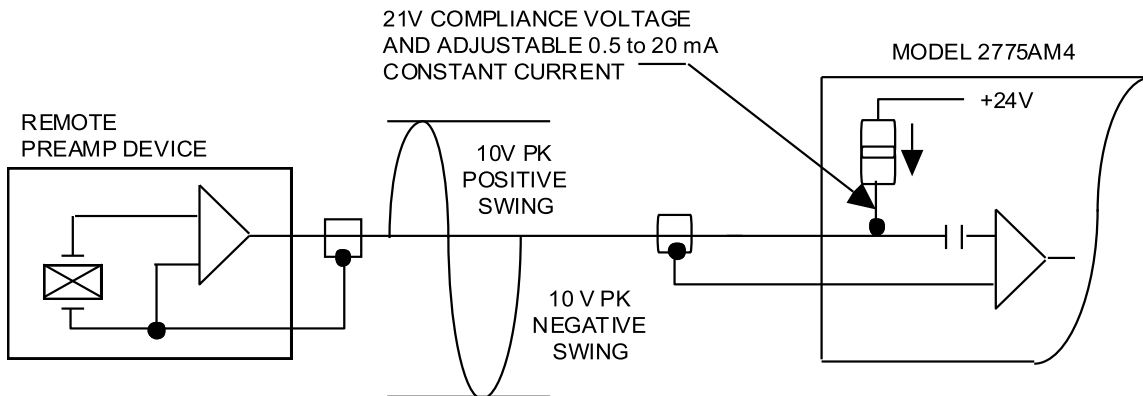

FIGURE 3-7: REMOTE HOOKUP

**ENDEVCO 2775AM4
INSTRUCTION MANUAL**

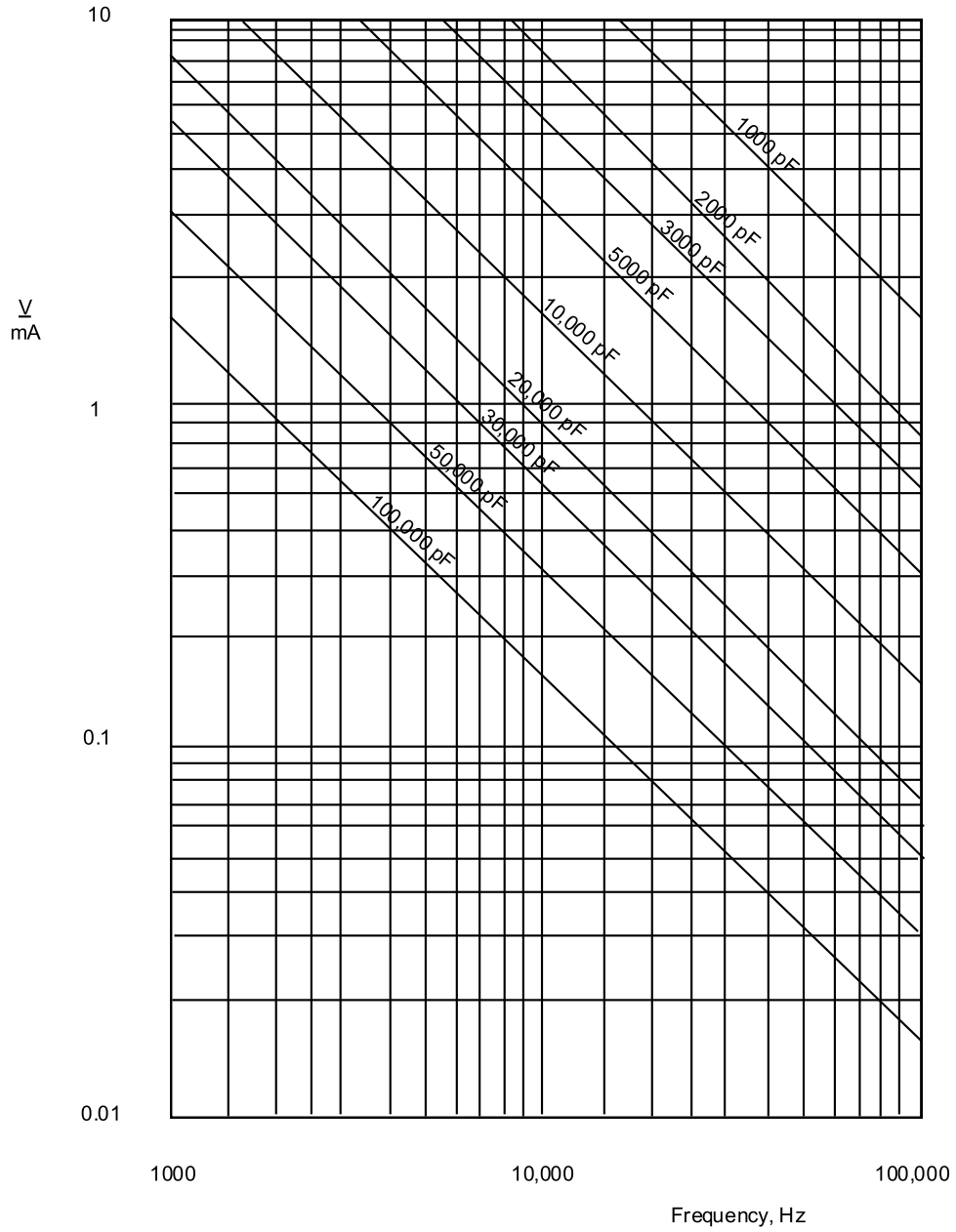

FIGURE 3-8: FREQUENCY RESPONSE NOMOGRAPH

**ENDEVCO 2775AM4
INSTRUCTION MANUAL**

**SECTION 4:
THEORY OF OPERATION**

1. CHARGE GENERATORS

Piezoelectric transducers are self-generating devices and require no electrical excitation. The electrical charge that is generated is proportional to the stress on the piezoelectric crystal. In an accelerometer, the output is proportional to acceleration; in a pressure transducer, the output is proportional to pressure, etc. For any transducer, the charge generated is independent of the amount of external capacitance attached to the transducer.

The simplified equivalent circuit of a piezoelectric or capacitive transducer is shown in Figure 4-1. The open circuit voltage is equal to the charge (q) divided by the transducer capacitance (C_p), $e_o = q/C_p$ where e_o is expressed in volts, q in pico coulombs, and C_p in picofarads. If the open circuit voltage is known, the charge can be calculated from $q = e_o C_p$.

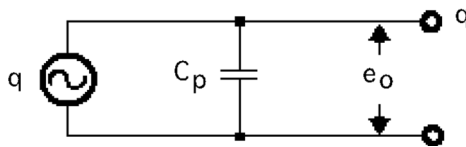

FIGURE 4-1. SIMPLIFIED EQUIVALENT CIRCUIT

All Endevco PE transducers are provided with a calibration certificate which specifies the charge sensitivity expressed in pico coulombs per unit measurand. For an accelerometer, the sensitivity is given in pC/g where:

$$Q_s = \frac{\text{pC}}{\text{g}} = \frac{\text{pC pk}}{\text{g pk}} = \frac{\text{pC rms}}{\text{g rms}}$$

For transducer sensitivities given only in terms of voltage, the charge sensitivity can be calculated from:

$$Q_s = \frac{E_{\text{cal}} (C_p + C_{\text{cal}})}{1000}$$

Where:

- Q_s = Charge sensitivity, in pC/g
- E_{cal} = Factory supplied voltage sensitivity, in mV/g
- C_p = Internal capacitance of transducer, in pF
- C_{cal} = external cable and amplifier capacitance, in pF

The values of E_{cal} , C_p , and C_{cal} are usually given on the calibration certificate. Since the charge sensitivity is not affected by capacitance connected external to the transducer, no additional calculations are necessary.

For example, the nominal voltage sensitivity (E_{cal}) of the Endevco Model 2272 Accelerometer is 4.0 mV/g, nominal capacitance is 2700 pF, and the accelerometer is calibrated with 300 pF of external capacitance. Thus, the nominal charge sensitivity is:

**ENDEVCO 2775AM4
INSTRUCTION MANUAL**

**ENDEVCO 2775AM4
INSTRUCTION MANUAL**

$$Q_s = \frac{4(2700 + 300)}{1000} = 12 \text{ pC/g}$$

2. CHARGE CONVERSION

The input circuit of the Model 2775AM4 consists of a charge converter which accepts the electrical charge from the transducer and converts it to a voltage proportional to the input charge. The charge converter is essentially a voltage amplifier with capacitance feedback, Figure 4-2. In operation, the output voltage which occurs as a result of the charge input signal is fed back through the feed-back capacitor C_f in such a direction as to maintain the voltage at the input at, or very close to, zero. Thus, the input charge is stored in the feedback capacitor, producing a voltage across it which is equal to the input charge divided by the capacitance of the feedback capacitor.

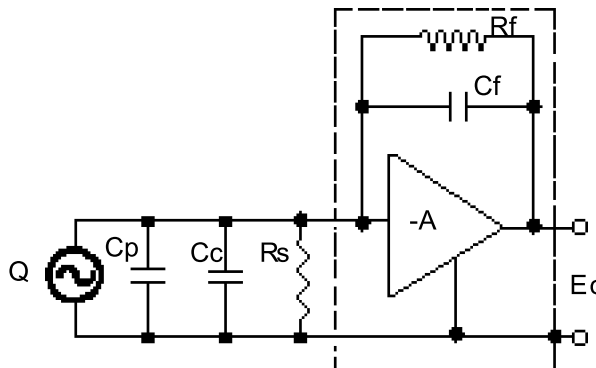

FIGURE 4-2. CHARGE CONVERTER CIRCUIT

The transfer characteristic (conversion gain in mV/pC) of the charge converter depends primarily on the value of the feedback capacitor. When the amplifier is operated within specification limits, the equation for conversion gain simplifies to the relationship:

$$\frac{E_o}{Q} = \frac{1}{C_f}$$

In effect, a charge converter is a circuit which appears to have a capacitance input impedance so large that the effect of varying input transducer or cable capacitance is insignificant. Thus, large variation of source capacitance is possible without any appreciable change in overall system sensitivity.

3. LOW FREQUENCY RESPONSE

In many applications, particularly when using transducers with ceramic crystals, it is desirable to eliminate quasi DC outputs which can be produced in the transducer due to pyroelectric effects. For most shock and vibration measurements, flat frequency response is required only at frequencies down to about 2 Hz. Thus, the addition of a feedback resistor R_f in parallel with the feedback capacitor results in control of the low frequency response of the circuit and a low frequency cutoff of:

**ENDEVCO 2775AM4
INSTRUCTION MANUAL**

$$f_c = \frac{1}{2 R_f C_f}$$

One of the advantages of the charge amplifier is that a desired low frequency response can be achieved in the amplifier design.

4. CIRCUIT DESCRIPTION

NOTE: See Figure 4-3 and refer to Schematic SC2775AM4 in Section 7.

The Model 2775AM4 Signal Conditioner can be regarded as comprising:

- A. An input stage (charge converter or preamp input conditioner),
- B. An isolation amplifier (for common mode rejection when needed),
- C. A sensitivity normalization stage,
- D. A gain stage,
- E. Gain control logic, and
- F. AC, DC, and Servo output stages. A 1 kHz internal oscillator is included to generate a CAL OUT signal, and a power supply furnishes all necessary power for circuit operation.

ENDEVCO 2775AM4 INSTRUCTION MANUAL

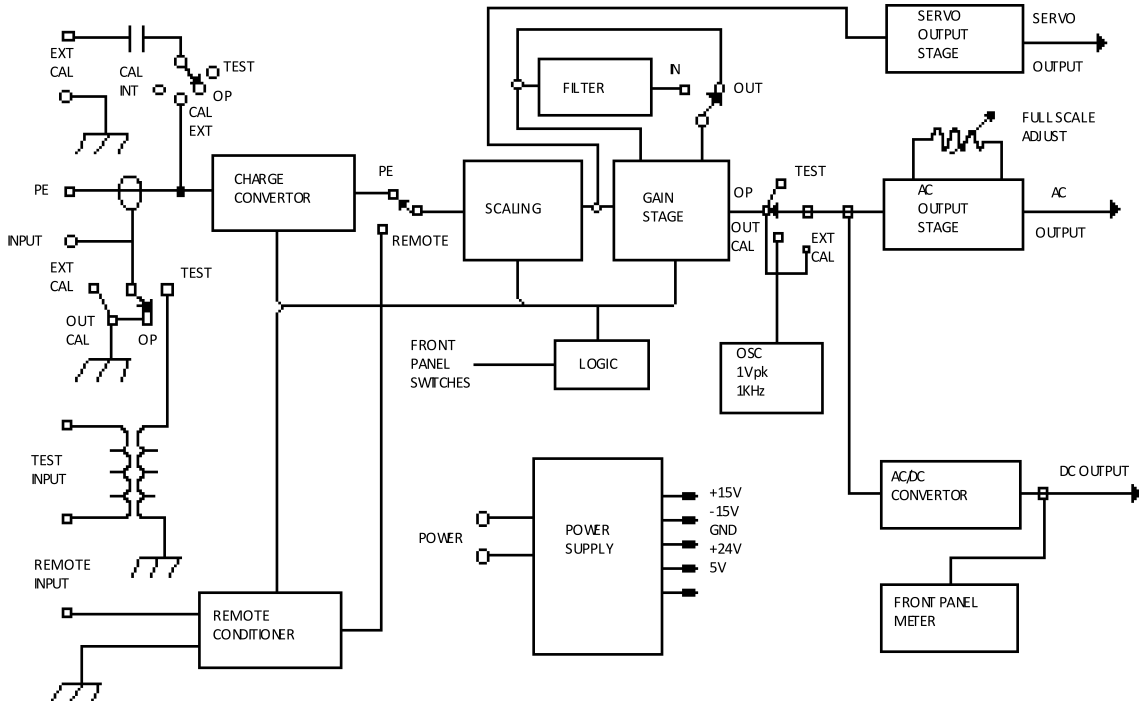

FIGURE 4-3: MODEL 2775AM4 BLOCK DIAGRAM

5. CHARGE CONVERTER

NOTE: See Schematic SC2775AM4

The function of the charge converter is to sense the charge applied at the PE input (J2) and to convert this charge to an analog voltage. The charge converter includes a high gain amplifier (Q3 and U3). Two different feedback capacitors establish the gain of the converter selected by a read only memory (ROM) or a programmable read only memory (PROM), on some earlier units. The gain is 1 or 0.1 mV/pC depending on the feedback capacitors (C6 or C7) connected into the circuit by the ROM switching logic. The charge converter receives a charge in pico coulombs (pC) and converts the signal to millivolts (mV) out.

The position of the Full Scale Range (g) selector switch S1 and Sensitivity Multiplier switch S2 provides encoded addresses for a read only memory (ROM U14). The ROM, in turn, provides outputs which determine the switch on/off positions that set amplifier gains. Refer to Table 4-1 for the full scale, sensitivity, multiplier and ROM output relationships.

**ENDEVCO 2775AM4
INSTRUCTION MANUAL**

FULL SCALE	SENSITIVITY MULTIPLIER	ROM OUTPUTS								ROM Pin#
		Front Panel Display					Amplifier Gain			
		D7	D6	D5	D4	D3	D2	D1	D0	
		I7	I6	I5	I4	I3	I1	I0	9	
10	.1	H	H	H	H	L	L	H	L	
30	.1	H	H	H	H	H	L	H	L	
100	.1	L	L	L	H	L	H	H	L	
300	.1	L	H	L	H	H	L	L	L	
1000	.1	H	L	L	H	L	H	L	L	
3000	.1	H	H	L	H	H	H	L	L	
1	1	H	L	L	L	L	L	H	H	
3	1	H	H	L	L	H	L	H	H	
10	1	H	H	H	H	L	H	H	H	
30	1	H	H	H	H	H	L	L	H	
100	1	L	L	L	H	L	H	L	H	
300	1	L	H	L	H	H	H	L	H	
0.1	10	L	L	L	L	L	L	H	H	
0.3	10	L	H	L	L	H	L	H	H	
1	10	H	L	L	L	L	H	H	H	
3	10	H	H	L	L	H	L	L	H	
10	10	H	H	H	H	L	H	L	H	
30	10	H	H	H	H	H	L	H	H	
0.1	100	L	L	L	L	L	H	H	H	
0.3	100	L	H	L	L	H	L	L	H	
1	100	H	L	L	L	L	H	L	H	
3	100	H	H	L	L	H	L	L	H	

TABLE 4-1: 2775AM4 MEMORY MAP

**ENDEVCO 2775AM4
INSTRUCTION MANUAL**

6. PREAMP INPUT CONDITIONER

NOTE: See Schematic SC2775AM4 and Figure 4-3

Transistor Q17 is a constant current supply for an integral electronics transducer or a remote charge converter (or a remote preamp). Potentiometer R4 and resistor R99 are biasing resistors which set the proper operating point for the circuit. The AC data signal from the remote device travels along the same wire carrying DC power to the device. R4 adjusts the constant current from 0.5mA to greater than 20mA and should not be adjusted higher than the current rating of preamp device.

The remote preamp device senses the charge generated by a piezoelectric transducer and converts the signal into a voltage. The AC signal from a remote preamp device (remote charge converter, preamp or Isotron transducer) is coupled through capacitor C3 to a buffer (Pin 10 of Op Amp U2A). The output of the buffer is applied to a switchable X1 or X.1 attenuator (R9 and R11) controlled by signal ISO-D1 which opens or closes switch Q2. The signal from the attenuator (X1 or X0.1) is buffered by U2C and U2D and coupled through switch U4B (actuated by S5 placed at REMOTE) to the isolation amplifier.

The positions of the front panel Full Scale Range selector switch S1 and Multiplier switch S2 provide addresses for ROM U14 which outputs the logic level (0 Vdc or 5 Vdc) commands which turn Q2 on or off. With Q2 turned off, the gain of the Op Amp U2C is X1 and that of U2D is always X1 for an overall gain of X1.

If Q2 is turned on, voltage divider action causes the gain of Op Amp U2C to be X0.1 and since U2C is still at a gain of X1, the overall gain is X0.1. The gains of this signal conditioner stage correspond to the same gains switched at the charge converter stage.

7. SENSITIVITY NORMALIZATION STAGE

NOTE: See Schematic SC2775AM4 and Figure 4-3

The output of the Isolation Amplifier is applied to the Sensitivity Amplifier at Pin 18 of U9. The Sensitivity Normalization stage is made up of thumbwheel switches, S6A, S6B, S6C, on the front panel and of U8A, U9A and U10A. The thumbwheel switch positions change the gain of the Sensitivity Normalization stage by a ratio expressed as:

$$\frac{10}{S}, \text{ where } S \text{ is the dialed-in sensitivity}$$

For example, if the dialed-in sensitivity is 1.00, this yields a gain of X10:

$$\text{Gain} = \frac{10}{1} = 10$$

If the sensitivity is set for 10.99, this yields a gain of X0.9091:

$$\text{Gain} = \frac{10}{10.99} = 0.9091$$

The three-wheel switch S6 in conjunction with gate U8A provides four digits.

**ENDEVCO 2775AM4
INSTRUCTION MANUAL**

From this stage, the output is applied to a gain stage (voltage amplifying/scaling for AC and DC out processing) and to the servo signal processing stages.

8. GAIN STAGE

NOTE: See Schematic SC2775AM4 and Figure 4-3.

The output of the Sensitivity Normalization stage is applied to the input of the gain stage (Voltage Amplifier) at Op Amp U12C. This Op Amp provides a gain of X1 or X10 depending on ROM control signal D2. (See Table 4-2.) A D2 low state provides a X10 gain and a high state switches Q7 on for a X1 gain. A plug-in type filter (if installed) is switched in or out by switch S7. The filter can be a lowpass, highpass or bandpass type. The filtered (or unfiltered) signal is coupled by C19 to Op Amp U12D which provides a gain of X1 or X3 depending on control signal D3. With D3 in the low state, the gain is X3. Signal D3 in the high state turns switch Q8 on to provide a gain of X1. The signal is then routed by mode switch S3 through a X3.4 gain amplifier (U17A) and a X1 buffer (U17B) to the AC and DC Out circuits. This voltage at the output of the voltage amplifier (GAIN) stage is scaled to 10.2 V pk full scale.

CONTROL	SWITCH	SWITCH STATE	GAIN
D2H	Q7	On	X1
D2L	Q7	Off	X10
D3H	Q8	On	X1
D3L	Q8	Off	X3

TABLE 4-2 VOLTAGE AMPLIFIER GAIN

9. SERVO AMPLIFIER

NOTE: See Schematic SC2775AM4 and Figure 4-3

The output of the Sensitivity Normalization stage is also applied to the input of the Servo Amplifier at buffer U10B. The Servo Amplifier maintains a 10 mV/g (or a 100 mV/g) servo output regardless of the front panel sensitivity and full scale settings for the signal conditioner. Different gain stages and voltage dividers are switched as required to keep the output scaled to 10 mV/g or 100 mV/g. (The placement of jumper W1 selects 10 or 100 mV/g scaling.) Refer to Table 4-3 for Servo Amplifier gain control information and to Table 4-1 and to schematic.

**ENDEVCO 2775AM4
INSTRUCTION MANUAL**

CONTROL	SWITCH	SWITCH STATE	GAIN
A6H	Q9	On	X0.1
A6L	Q9	Off	X1
D1H	Q6	On	X1
D1L	Q6	Off	X10
A8L	Q10	On	X0.1
A8H	Q10	Off	X1
D0H	Q11	On	X1
D0L	Q11	Off	X10
	W1 (Jumper) Open		X1
	W1 (Jumper) Closed		X10

TABLE 4-3: SERVO AMPLIFIER GAIN CONTROLS

10. AC AND DC OUTPUT STAGE

NOTE: See Schematic SC2775AM4 and Figure 4-3

The output from buffer U17B provides a 10.2 V pk full scale signal to the output circuits. This signal voltage is applied to potentiometer A2R4 and resistor A2R5 to adjust for a 1 to 10 V pk full scale AC OUT output from buffer U17, U22.

An AC-to-DC converter consisting of U16C and D takes the 10.2 V pk full scale signal and converts it to average DC. A gain factor in the circuit scales the voltage level to provide 10 Vdc out full scale. The analog front panel meter is driven from the DC output to indicate percent of full scale.

11. INTERNAL OSCILLATOR

When switch S3B is placed at OUT CAL, the Internal Oscillator is switched on via opto-isolator U21B and Q18. A signal of fixed amplitude is routed to the output stages to provide a simulated full scale output. The Internal Oscillator is comprised of U15, U19A, U19B, U19C, U19D, U16A and U16B. The reference for the oscillator is set by the 5 V pk output of U15. The 1 kHz oscillator signal output from U16A is 5 V dc. This 5 V pk output is reduced by voltage divider R68/R65 for a 3 V pk output from buffer U16B. This output is then routed, through the OUT CAL position of switch S3B, to X3.4 Op Amp U17A for a 10.2 V pk output which is applied to the AC and DC output circuits. (When the switch is at OUT CAL, all inputs from the front end of the signal conditioner are disconnected from the output circuit.)

**ENDEVCO 2775AM4
INSTRUCTION MANUAL**

12. POWER SUPPLY

Power supply description follows. A center-tapped secondary winding of transformer T2 is used to step down the voltage for power supply. The AC voltage from the secondary winding is applied to rectifier CR34. The rectifier plus and minus voltages out of CR34 are filtered by capacitors C40 and C41 and are applied to dual polarity tracking ± 15 V regulator U25. Resistors R95 and R97 establish the current sensing necessary to limit the power supply output currents during an overload or short circuit condition. Voltage sensing for output voltage regulation takes place at Pins 6 and 14. Transistors Q15 and Q16 add current boost to the \pm outputs. Capacitors C33 and C34 filter the outputs.

Regulator U23 furnishes a regulated +5V output for logic circuits. A separate +24V power supply furnishes power to a remote device such as a Remote Charge Converter or to an Isotron transducer. The supply receives the rectified voltage from full-wave rectifier CR32. This voltage is applied to voltage regulator U1 which provides a 24V output. Resistor R101 connected between the ADJ and OUT terminals permits the regulator to function as a precision current regulator which supplies constant current for a Remote Charge Converter or IE transducer through transistor Q17.

13. SPECIFICATIONS

Specifications for the Model 2775AM4 Signal Conditioner are contained in the data sheet located in the back of this manual.

**ENDEVCO 2775AM4
INSTRUCTION MANUAL**

**SECTION 5:
MAINTENANCE/CALIBRATION**

1. MAINTENANCE

The Endevco Model 2775AM4 Signal Conditioner is maintenance free. The calibration procedure is recommended to be performed on a six month periodic basis.

2. CALIBRATION

The 2775AM4 is designed for minimal adjustments for calibration. The unit has four adjustment potentiometers that are the AC ADJ (A2R4), the constant current adjustment (R4) and the two common mode adjustments (R37 & R39). Selected portions of the calibration procedure can be used for troubleshooting described in paragraph 5.16.

A. EQUIPMENT REQUIRED

The following equipment is required for unit check-out and calibration.

DVM True rms voltmeter with $\pm 0.1\%$ accuracy or better
(Fluke Model 8050A or equivalent)

Oscilloscope General purpose oscilloscope 50MHz bandwidth
(Tektronix Model 2213A or equivalent)

Signal Generator Synthesizer/Function Generator 0.1Hz to 1MHz
(Hewlett Packard Model 3310A or equivalent)

Frequency Counter General purpose frequency counter
(Fluke Model 1900A or equivalent)

Capacitor Shielded Precision Capacitor 1000 pF $\pm 1\text{pF}$
(Endevco Model 2947B-2 $\pm 1\%$ labeled to $\pm 1\text{pF}$)

Bandpass Filter 2 - 20kHz

Standard parts	Desired Component	Nearest Standard Value
	30,000 pF $\pm 5\%$ capacitor	30,000 pF $\pm 5\%$
	5,000 pF $\pm 5\%$ capacitor	4,700 pF $\pm 5\%$ (suggest 4,700 pF and 270 pF)
	120 Ω $\pm 1\%$ 1W resistor	120 Ω $\pm 5\%$ 1W
	250 Ω $\pm 1\%$ resistor	249 Ω $\pm 1\%$
	3.32k Ω $\pm 1\%$ resistor	3.32k Ω $\pm 1\%$
	10 M Ω $\pm 1\%$ resistor	10 M Ω $\pm 5\%$
	1N963B 12V zener diode	
	TLO72CP op amp	
	Shielded component box	2 required

ENDEVCO 2775AM4 INSTRUCTION MANUAL

3. INITIAL SETUP

- A. Remove the top cover by removing the four screws on the top of the unit. On the front panel, (Figure 5-1) set the following controls as indicated:

SENSITIVITY switch (S6) to 10.00
 MULTIPLIER switch (S2) to 1
 FULL SCALE switch (S1) to 100
 FUNCTION switch (S3) to OP
 FILTER switch (S7) to OUT

- B. On the back panel (Figure 5-2) set the INPUT MODE switch (J5) to PE.

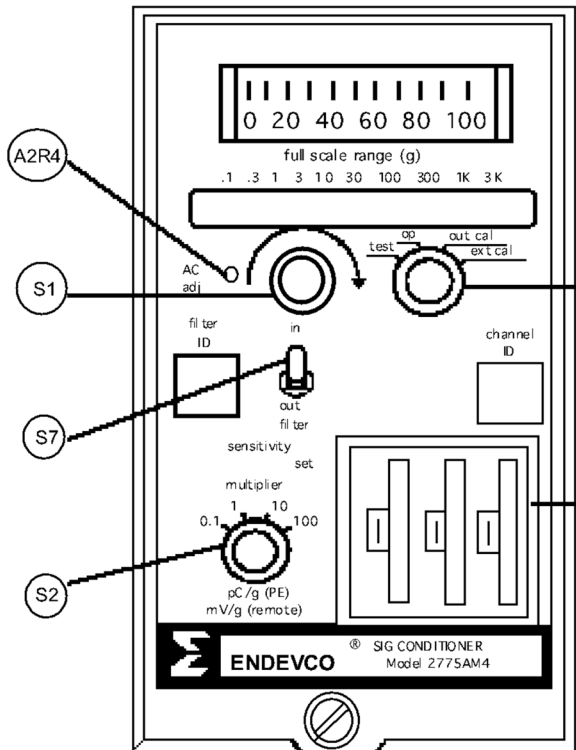

FIGURE 5-1: FRONT PANEL CONTROLS

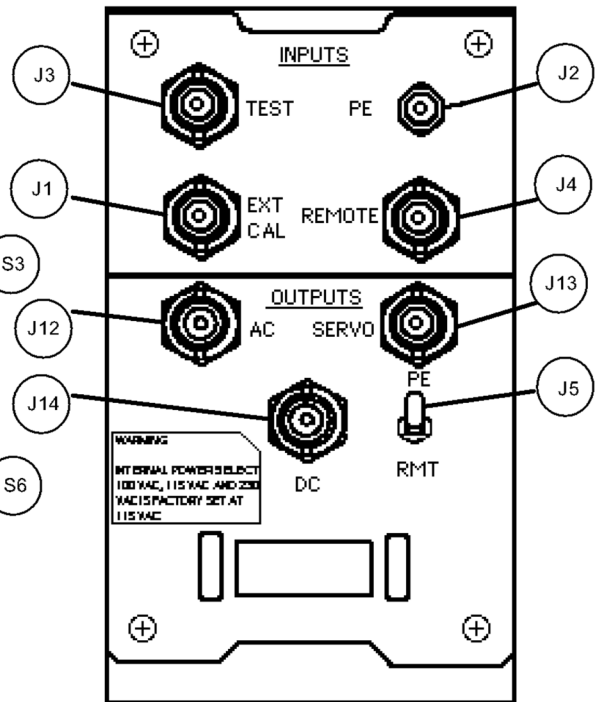

FIGURE 5-2: REAR PANEL CONTROLS

ENDEVCO 2775AM4 INSTRUCTION MANUAL

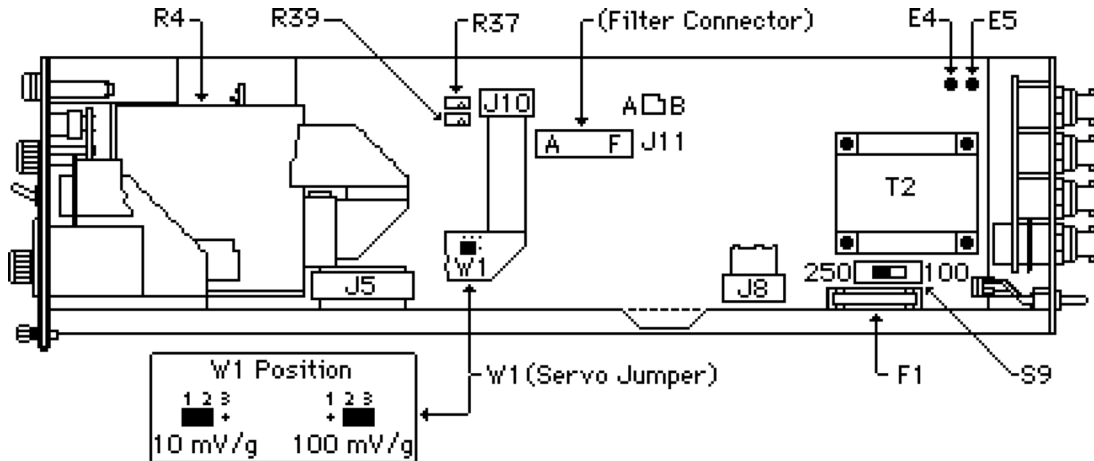

FIGURE 5-3: INTERNAL CONTROLS

- C. Insure the LINE INPUT SWITCH (S9), located on the main circuit board, is set to proper line voltage. (The unit is factory set for 110Vac). Apply power and check the regulated power supplies for the proper voltages (see Figure 5-4). This unit contains one ± 15 Volt supply:

+24 Vdc $\pm 7\%$ +5 Vdc $\pm 6\%$
 +15 Vdc $\pm 6\%$

NOTE: If the test equipment used has floating inputs, the output ground and chassis ground must be connected to avoid 60 Hz pick-up. The connection can be made on the circuit board at E4 and E5 or use a jumper from an output connector shell to the chassis. This is important for proper reading of noise and low level signals.

ENDEVCO 2775AM4 INSTRUCTION MANUAL

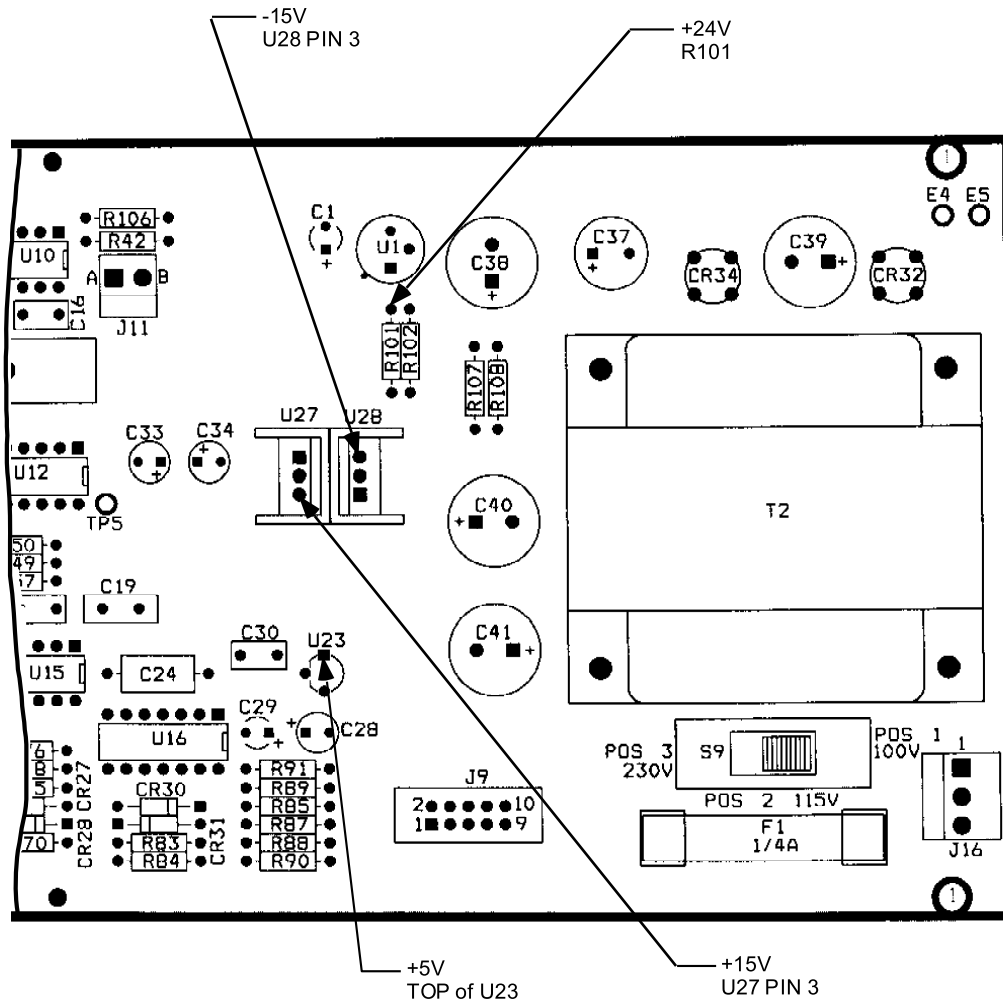

FIGURE 5-4: POWER SUPPLY TEST POINTS

4. OUTPUT CALIBRATION

- A. Set FUNCTION switch to OUT CAL and monitor the AC OUTPUT (J12) with a frequency counter to verify a frequency between 950 and 1050 Hz. Monitor the DC OUTPUT (J14) for 10.0 Vdc + 150 mVdc (see Figure 5-5).
- B. Monitor the AC OUTPUT with a DVM in the ac rms mode. The output level should be 7.07 Vrms + 70 mV adjustable by the front panel AC ADJ (A2R4). Adjust the AC ADJ ccw to greater than 7.07 Vrms and then cw to less than 0.707 Vrms, this verifies the operation of the AC ADJ potentiometer. Set the AC ADJ for .707 Vrms + 1% for the next step.

ENDEVCO 2775AM4 INSTRUCTION MANUAL

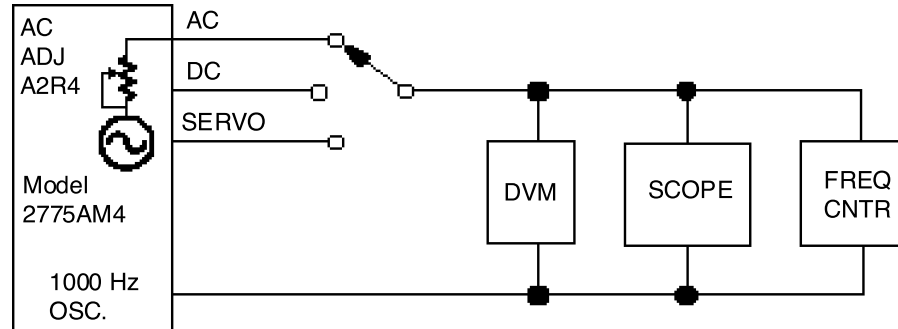

FIGURE 5-5: OUTPUT CALIBRATION

5. TEST INPUT

Set the FUNCTION switch (S3) to TEST and the SENSITIVITY switch to 1.00. Connect a shielded 1000 pf $\pm 1\%$ capacitor across the PE INPUT and apply a 70.7 mVrms 1 KHz signal to the TEST INPUT. Set the FULL SCALE switch to 100 and measure the AC OUTPUT using a DVM for approximately a full scale output. (See Figure 5-6)

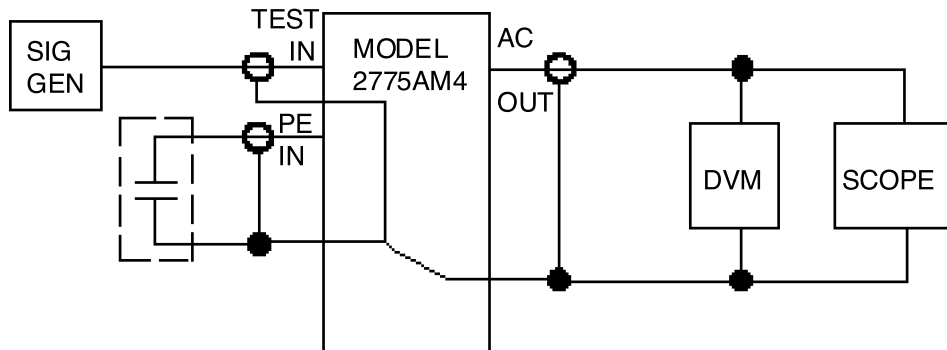

FIGURE 5-6: TEST INPUT

6. EXTERNAL CAL INPUT

NOTE: THIS STEP MUST BE DONE FOR CALIBRATION ACCURACY

Set the FUNCTION switch to OUT CAL and the FULL SCALE switch to 100. Measure the ac amplitude at U17 pin 7, and adjust the AC ADJ for exactly this ac reading times 0.9852 at the AC OUT. Set the FUNCTION switch to EXT CAL and apply a 70.7 mVrms 1kHz signal to the EXT CAL INPUT (J1). Measure the AC OUTPUT (J12) for a 7.07 Vrms $\pm 2\%$ reading. Keep present setup for the next test.

ENDEVCO 2775AM4 INSTRUCTION MANUAL

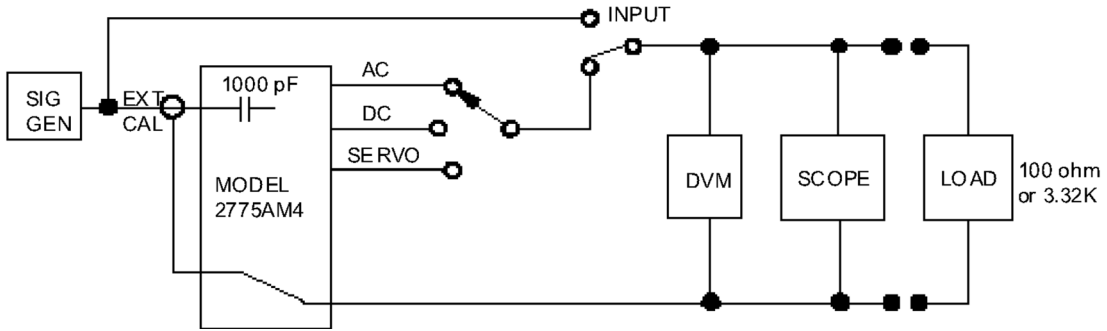

FIGURE 5-7: EXTERNAL CALIBRATION

7. MAX I OUT

- A. Measure and record the full scale AC OUTPUT, SERVO OUTPUT, and DC OUTPUT voltages.
- B. Connect a 120 ohm 1 watt resistor across the AC OUTPUT and measure the voltage, then compare the the loaded reading to the unloaded reading. The difference between the two readings should be less than 1%.
- C. Connect a 3.32K ohm resistor across the SERVO OUTPUT and compare the voltage to the first reading. The difference between the two readings should be less than 1 %.
- D. Connect the 3.32K ohm resistor across the DC OUTPUT and measure the DC voltage to compare to the first reading. The difference between the two readings should be less than 1%.

8. NOISE/DC OFFSET

Set the FULL SCALE switch to 10 and the FUNCTION switch to OP. Place a non-shorting cap on the PE INPUT (See Figure 5-8). Measure the following outputs through a 2Hz to 20KHz bandpass filter. Be sure to disconnect/disable signal applied to EXT CAL input prior to noise test.

	NOISE	DC OFFSET
AC OUTPUT	50 mV rms max	20 mVdc max
w/o BP Filter	300 mV pk-pk max	
SERVO OUTPUT	2 mV rms max	17 mVdc max
DC OUTPUT	-	85 mVdc max
METER READING	Must be less than 3% deflection	

ENDEVCO 2775AM4 INSTRUCTION MANUAL

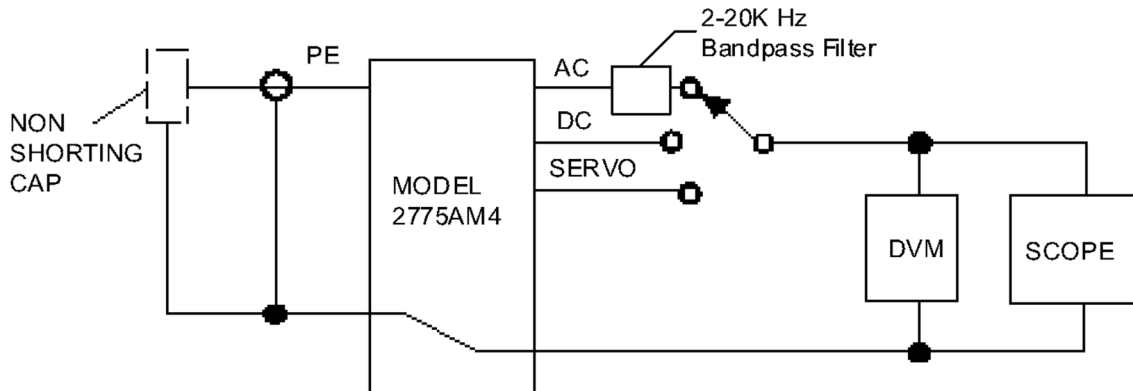

FIGURE 5-8: NOISE

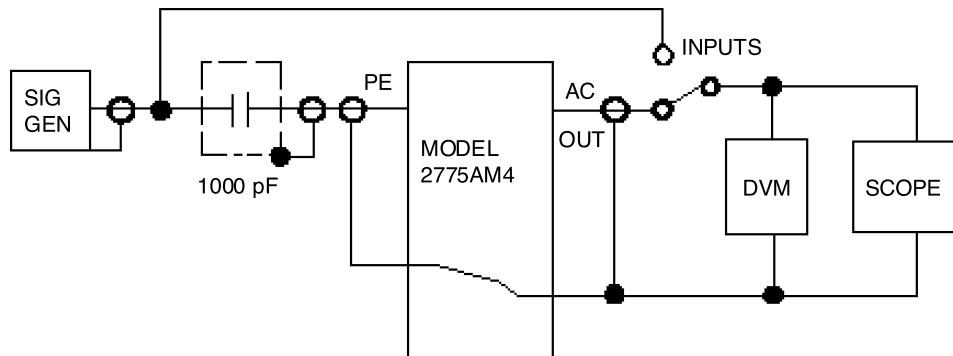

FIGURE 5-9: GAIN ACCURACY

9. GAIN ACCURACY

NOTE: For gain accuracy, the AC ADJ must be calibrated as follows:

- A. Set the FUNCTION switch to OUT CAL.
- B. Adjust AC OUT for exactly the measured ac amplitude at U17 pin 7 times 0.9852. Set FUNCTION switch to OP.

Remove the cap from the PE INPUT and connect a 1kHz sine wave signal through the shielded 1000 pF ± 1 pF capacitor to the PE INPUT (see Figure 5-9). The EXT CAL input, (figure 5-7) internal to the unit can be used if a precision capacitor, (Figure 5-7), is not available, but the accuracy becomes $\pm 2\%$ (6.93-7.21 Vrms). The accuracy is $\pm 2\%$ because of the $\pm 0.5\%$ accuracy of the calibration capacitor internal to the unit. Set the input levels corresponding to the FULL SCALE switch and MULTIPLIER switch settings, according to the following:

ENDEVCO 2775AM4 INSTRUCTION MANUAL

INPUT <u>mV rms</u>	MULTIPLIER <u>switch</u>	FULL SCALE <u>switch</u>	AC OUTPUT <u>limits (Vrms)</u>	DC OUTPUT <u>limits (Vdc)</u>	SERVO OUTPUT <u>limits (mVrms)</u>
212.1	0.1	3k	6.96-7.18	9.85-10.15	
212.1	1	300	6.96-7.18	9.85-10.15	
212.1	10	30	6.96-7.18	9.85-10.15	
212.1	100	3	6.96-7.18	9.85-10.15	
70.7	0.1	1K	6.96-7.18	9.85-10.15	6690-7180
70.7	1	100	6.96-7.18	9.85-10.15	696-718
70.7	10	10	6.96-7.18	9.85-10.15	69.6-71.8
70.7	100	1	6.96-7.18	9.85-10.15	6.96-7.18
21.2	0.1	300	6.96-7.18	9.85-10.15	
21.2	1	30	6.96-7.18	9.85-10.15	
21.2	10	3	6.96-7.18	9.85-10.15	
21.2	100	0.3	6.96-7.18	9.85-10.15	
7.07	0.1	100	6.96-7.18	9.85-10.15	
7.07	1	10	6.96-7.18	9.85-10.15	
7.07	10	1	6.96-7.18	9.85-10.15	
7.07	100	0.1	6.96-7.18	9.85-10.15	
2.12	0.1	30	6.96-7.18	9.85-10.15	
2.12	1	3	6.96-7.18	9.85-10.15	
2.12	10	0.3	6.96-7.18	9.85-10.15	
0.707	0.1	10	6.96-7.18	9.85-10.15	
0.707	1	1	6.96-7.18	9.85-10.15	
0.707	10	0.1	6.96-7.18	9.85-10.15	

10. SENSITIVITY SWITCH TEST

Use the previous setup and set FULL SCALE switch to 100, set the MULTIPLIER switch to 1 and input a 1 KHz signal with the value corresponding to the SENSITIVITY switch setting.

INPUT <u>mV rms</u>	SENSITIVITY <u>switch</u>	AC OUTPUT <u>limits</u>
141.4	2.00	6.96-7.18 Vrms
282.8	4.00	6.96-7.18 Vrms
424.2	6.00	6.96-7.18 Vrms
565.6	8.00	6.96-7.18 Vrms
707.1	10.00	6.96-7.18 Vrms
777.1	10.99	6.96-7.18 Vrms

ENDEVCO 2775AM4 INSTRUCTION MANUAL

11. FREQUENCY RESPONSE

- A. The low frequency response must be measured using an oscilloscope or a special low frequency measurement device (such as a Solartron 1250 Frequency Response Analyzer). Set the SENSITIVITY switch to 1.00 and the FUNCTION switch to OUT CAL and adjust the AC OUTPUT for 1.000 Vrms. Set the FUNCTION switch to OP and adjust the signal input level to the 1000 ±1 pF shielded capacitor to read 1.00 Vrms at the AC OUTPUT (see Figure 5-10). Adjust the frequency and make the following readings:

<u>INPUT frequency</u>	<u>PER CENT deviation</u>
1KHz	REF
1.8-2.2 Hz	-5%
0.1-0.6 Hz	-3dB

- B. The high frequency roll off is determined by the full scale range selected in combination with the multiplier and sensor. Set the AC OUTPUT to 1.00 Vrms at 1kHz for the reference frequency point. Increase the frequency until the AC OUTPUT drops to the -5% point and record the frequency, next increase the frequency until the AC OUTPUT drops to the - 30% (-3dB) point and record the frequency. Readjust the AC OUTPUT reference to 1.00Vrms at 1kHz for each full scale range. The frequency recorded should be greater than the frequency listed for each full scale range. (See Figure 5-11 for Setup.)

<u>FULL SCALE switch</u>	<u>AC OUTPUT reference</u>	<u>AC OUTPUT -5% point</u>	<u>AC OUTPUT -30% point</u>
1	1 kHz	25 kHz	70 kHz
3	1 kHz	25 kHz	70 kHz
10	1 kHz	25 kHz	70 kHz
30	1 kHz	30 kHz	100 kHz
100	1 kHz	35 kHz	120 kHz
300	1 kHz	35 kHz	120 kHz

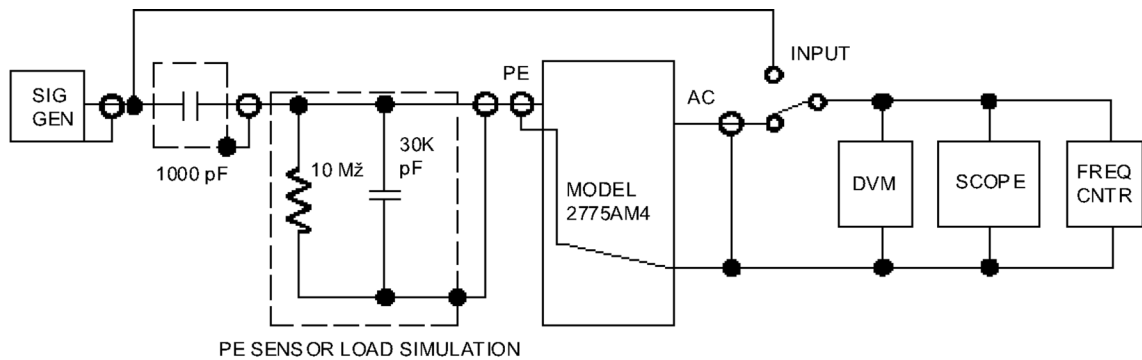

FIGURE 5-10: FREQUENCY RESPONSE

ENDEVCO 2775AM4 INSTRUCTION MANUAL

12. REMOTE GAIN ACCURACY

Set the FUNCTION switch to OUT CAL and the FULL SCALE switch to 3K. Measure the ac amplitude at U17 pin 7 and adjust the AC ADJ for exactly this ac reading times 0.9852 at the AC OUT. Set the FUNCTION switch to OP and set the back panel MODE switch to RMT and connect a 1 KHz sine signal through the current blocking circuit (Figure 5-11) to the REMOTE INPUT (J4). Set the MUTIPLIER switch to 1 and set the FULL SCALE switch per the following table:

<u>INPUT</u> mV rms	<u>FULL SCALE</u> switch	<u>AC OUTPUT</u> limits
212.1	300	6.96-7.18 Vrms
70.7	100	6.96-7.18 Vrms
21.2	30	6.96-7.18 Vrms
7.07	10	6.96-7.18 Vrms

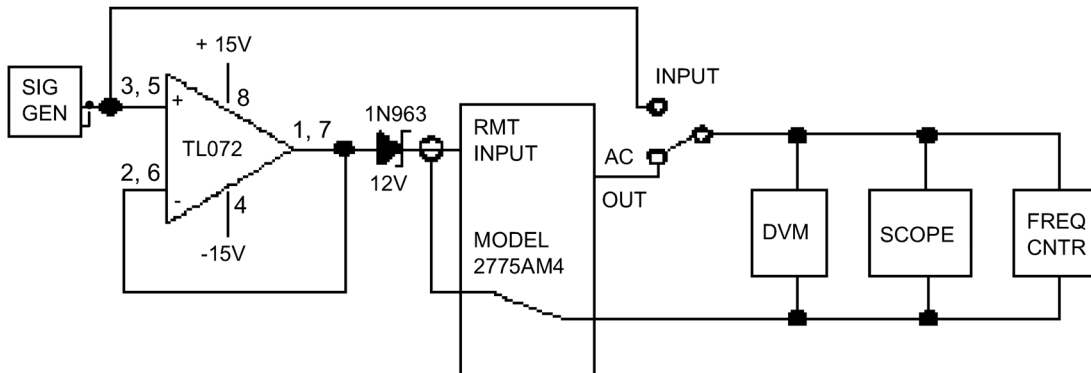

FIGURE 5-11: REMOTE GAIN

13. REMOTE FREQUENCY RESPONSE

The low frequency response must be measured using an oscilloscope or a special low frequency measurement device (such as a Solartron 1250 Frequency Response Analyzer). Use the previous setup. Set the FULL SCALE switch to 100. Set sensitivity to 1.00. Set multiplier to 1.0. Set the FUNCTION switch to OP and adjust the input level to read 1.000 Vrms at the AC OUTPUT. Adjust the frequency and make the following readings:

<u>INPUT</u> frequency	<u>PER CENT</u> deviation
1 KHz	REF.
.5 Hz MAXIMUM	-5%

ENDEVCO 2775AM4 INSTRUCTION MANUAL

The high frequency roll off is determined by the full scale range selected in combination with the multiplier. Set the AC OUTPUT to 1.00 V rms at 1 KHz for the reference frequency point. By adjusting the input source increase the frequency until the AC OUTPUT drops to the -5% point and record the frequency, next increase the frequency until the AC OUTPUT drops to the - 30% (-3dB) point and record the frequency. Readjust the input source until the AC OUTPUT reference is 1.00 Vrms at 1 KHz for each full scale range. The frequency recorded should be greater than the frequency listed for each full scale range (Figure 5-11).

<u>FULL SCALE switch</u>	<u>AC OUTPUT reference</u>	<u>AC OUTPUT -5% point</u>	<u>AC OUTPUT -30% point</u>
1	1 KHz	35 KHz	70 KHz
3	1 KHz	35 KHz	70 KHz
10	1 KHz	35 KHz	90 KHz
30	1 KHz	35 KHz	90 KHz
100	1 KHz	45 KHz	100 KHz
300	1 KHz	45 KHz	100 KHz

14. REMOTE NOISE

Remove the input signal from the REMOTE INPUT and connect a 250 ohm resistor and a 5000 pF capacitor in parallel across the REMOTE INPUT (see Figure 5-12). Set the FULL SCALE switch to 10. Be sure the REMOTE constant current source is set to 4ma dc. The bandwidth of the rms noise measurement is 2 to 20 KHz. Set FUNCTION switch to OUT CAL and adjust AC Output for 1 v pk at AC out. Set the FUNCTION switch to OP.

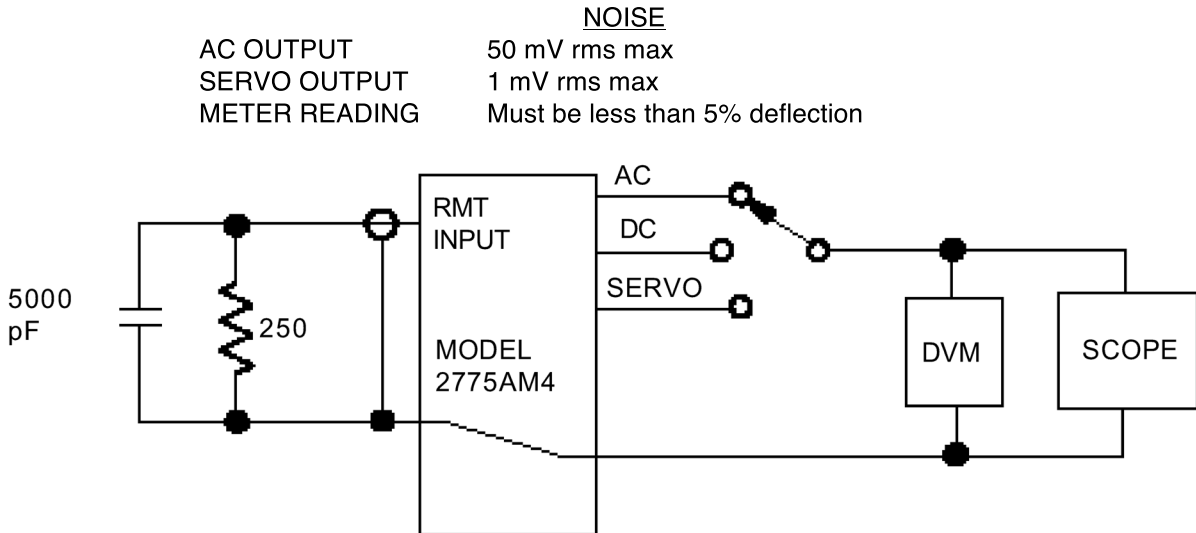

FIGURE 5-12: REMOTE NOISE

ENDEVCO 2775AM4 INSTRUCTION MANUAL

15. CONSTANT CURRENT ADJUST

Connect a DVM in the DC current mode to the REMOTE INPUT (J4) (See Figure 5-13). Adjust the constant current adjust R4 through the hole in the shield on the main circuit board (see figure 5-4) for a range of 0.5 mA to 20 mA. The current is factory set at 4 mA for Isotron accelerometer operation, but should be set for operational requirements (see 3.4.13) if other devices or long input lines are used.

NOTE: R4 can be adjusted to greater than 20 mA which could damage Isotron accelerometers. Do not leave current adjusted higher than 20 mA.

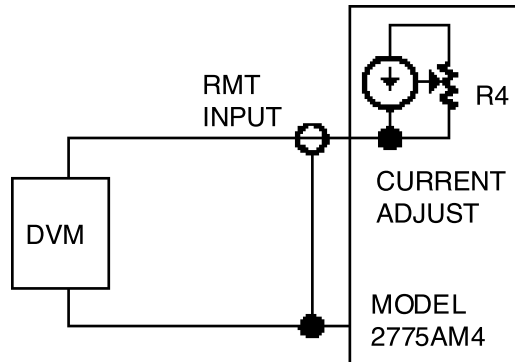

FIGURE 5-13: CONSTANT CURRENT ADJUSTMENT

16. TROUBLESHOOTING GUIDE

<u>Symptoms</u>	<u>Checks</u>
No indicator LEDs on any range	<ol style="list-style-type: none"> 1. Check power cord and line power. 2. Check fuse F1 on main circuit board. 3. Check power supply voltages see section 5.2.3.
LEDs out on some ranges	<ol style="list-style-type: none"> 1. Check U20 and replace if faulty. 2. Check U14 logic IC. See table 4-1.
LEDs on, but no output	<ol style="list-style-type: none"> 1. Set FUNCTION switch to OUT CAL and check AC OUTPUT. See paragraph 5.3.
No OUT CAL signal at AC OUTPUT	<ol style="list-style-type: none"> 1. Check U17 & U22 output stage. 2. Check U16 oscillator output see paragraph 4.2.9.
OUT CAL signal good, but no signal output	<ol style="list-style-type: none"> 1. Set FILTER switch to OUT and Check for signal. If the filter jumper is installed the FILTER switch has no effect. 2. Perform Ext Cal test paragraph 5.6.

ENDEVCO 2775AM4 INSTRUCTION MANUAL

<u>Symptoms</u>	<u>Checks</u>
Ext Cal test good, but no signal output.	<ol style="list-style-type: none">1. Check input cable to the for continuity and proper hookup.2. Check accelerometer for correct capacitance & resistance readings.3. Perform the TEST function see paragraph 3.4.5.
PE operation good, but no signal output.	<ol style="list-style-type: none">1. Insure the remote input device is a REMOTE signal output is a constant current type i.e. Isotron accelerometer or remote charge convertor.2. Check the REMOTE INPUT see paragraph 5.12 & 5.15.
No output with REMOTE or PE input.	<ol style="list-style-type: none">1. Check isolation stage of the unit, refer to paragraph 4.2.3.2. Check the gain stage of the unit, refer to paragraph 4.2.6.
REMOTE operation good, but PE operation bad	<ol style="list-style-type: none">1. Check charge converter section, refer to paragraph 4.2.1
Line frequency noise on the output signal.	<ol style="list-style-type: none">1. Check for ground loops in the system see paragraph 2.4.32. Insure the EXT CAL INPUT has a shorting cap or is connected to a low impedance source such as a function generator.3. Check that the output ground is connected to third wire ground through external equipment or install a jumper at E4 & E5 on the circuit board paragraph 2.2.3.
Output readings appear too high or low.	<ol style="list-style-type: none">1. Check AC ADJ paragraph 5.3.2.2. Check gain accuracy paragraph 5.9.3. Perform the SENSITIVITY switch test paragraph 5.10.4. Verify accelerometer calibration
AC OUTPUT readings good but the meter reading is off.	<ol style="list-style-type: none">1. Check the DC OUTPUT by the OUT CAL test paragraph 5.3.1.2. Check meter and connections.

17. REPAIR

Access to component parts and sub-assemblies is gained by removal of the unit's top cover. Further disassembly and re-assembly for repair is easily accomplished. Section 7 provides part location diagrams and parts lists for electrical components. Standard good workmanship practices should be employed for removal and replacement of components.

**ENDEVCO 2775AM4
INSTRUCTION MANUAL**

18. FACTORY SERVICE

If serious trouble occurs, and the instrument cannot be adjusted or repaired to meet specifications, return the amplifier to the factory. It should always be accompanied by a detailed statement describing the fault noted.

Endevco warrants each new instrument to be free from defects in material and workmanship for one year from the date of sale to the original purchaser. This warranty does not extend to units that have been mistreated, used in violation of Endevco recommendations, or to units that have been altered or repaired outside of Endevco's factory. Defects covered by this warranty will be corrected at no charge when the unit is delivered to the factory with all transportation charges prepaid. If, upon examination, it is found that a defect is not within the scope of this warranty, a statement of repair charges and a request for authorization to proceed with repair will be submitted to the purchaser.

See the complete warranty enclosed with this manual. Address all shipments and correspondence to:

ENDEVCO
Technical Services Dept.
30700 Rancho Viejo Rd.
San Juan Capistrano, CA
92675

**ENDEVCO 2775AM4
INSTRUCTION MANUAL**

**SECTION 6:
OPTIONS AND ACCESSORIES**

1. ACCESSORIES INCLUDED

The following accessory items are included with the Model 2775AM4:

<u>QTY</u>	<u>ITEM</u>
1	17180 Power Cord Assembly or 17180V Power Cord Assembly for 230-volt line power.
1	BNC to MICRODOT (10-32 thread) Adaptor Plug, Endevco P/N EJ21. This adapter plug permits the use of a cable with a Microdot 10-32 thread connector.

2. ACCESSORIES AVAILABLE

The following accessories for use with the Model 2775AM4 are available:

Model 2771A-X Remote Charge Converter	Converts high impedance pC charge input to a low impedance mV output. Three gain ranges are available; X= 0.1, 1 or 10.
Model 4948 Rack Adapter (6-channel)	Houses from one to six Model 2775AM4 Signal Conditioners. Each signal conditioner plugs into a power receptacle at the rear of the rack adapter.

Individual signal conditioners are held in place on the adapter by the knurled captive screw mounted on the front panel. Blank panels, P/N 16678, may be used to cover vacant slots. A power switch on the front panel applies power to all signal conditioners in the adapter. The Model 4948 is designed to fit a 19-inch rack cabinet.

Blank Panels P/N 16678	Blank panels for covering empty channel slots in the Model 4948 Rack Adapter.
Adjustable Filter Card P/N 35771	Plug-in type filter for processing of data signals. Adjustable to act as a high-pass, low-pass, or bandpass filter. Has selectable cut-off frequencies.

3. ADJUSTABLE FILTER

An adjustable filter card, P/N 35771, is available for use in the Model 2775AM4. This plug-in filter card is adjustable by moving a DIP programming jumper to form two high-pass, seven low-pass, or a bandpass filter from any combination of high-pass and low-pass filters on the card. The card also includes two unpopulated resistor positions for customer installation (or factory ordered installation) of filters with customized frequencies. The filters are active type, 2-pole Butterworth and are non-inverting in phase. The selectable cut-off frequencies for the adjustable filter are:

ENDEVCO 2775AM4 INSTRUCTION MANUAL

HP Cut-Off
Frequencies -5%
Custom
2 Hz
10 Hz

LP Cut-Off
Frequencies -5%
Custom
100 Hz
200 Hz
500 Hz
1000 Hz
2000 Hz
5000 Hz
10 000 Hz

A. FILTER PROGRAMMING

A low-pass, high-pass, or bandpass filter can be programmed. To program a low-pass (LP) filter or a high-pass (HP) filter on the Programmable Filter Card:

1. Place a DIP jumper at the proper position to select the mode, i.e., LP (low-pass) or HP (high-pass). (See Figure 6-1).
2. Install another jumper to select the desired high-pass or low-pass cut-off (corner) frequency. (See Figure 6-1).

To program a bandpass (BP) filter:

- 1 Place a DIP jumper at the BP position to select the bandpass mode.
2. Install two jumpers to select a cut-off frequency from the low-pass (LP) filter section and a cut-off frequency from the high-pass (HP) filter section. (See Figure 6-1).

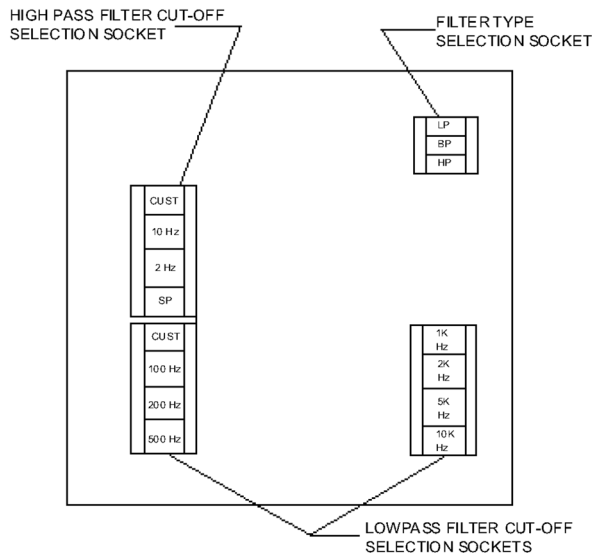

FIGURE 6-1: JUMPER POSITIONS

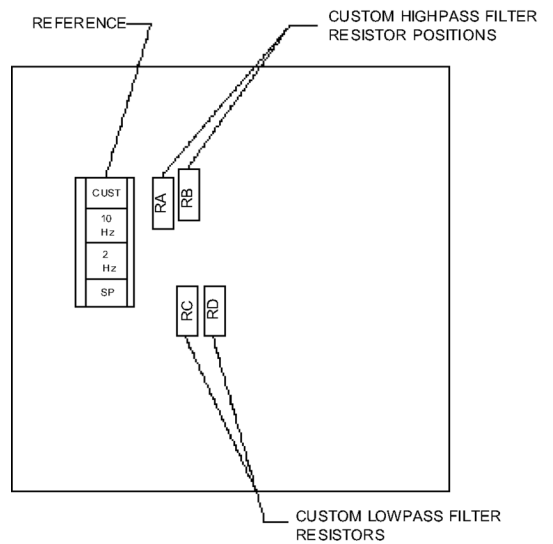

FIGURE 6-2: RESISTOR POSITIONS

B. SELECTING CUSTOM HIGH-PASS CUT-OFF FREQUENCIES.

Cut-off frequencies for a 2 Hz to 200 Hz high-pass filter range can be selected. To establish a desired -5% cut-off (corner) frequency for a customized high-pass, 2-pole Butterworth filter:

**ENDEVCO 2775AM4
INSTRUCTION MANUAL**

1. Select a desired cut-off frequency and, using Figure 6-3, first determine the resistance value of resistors RA.
2. Double the value of RA to find the resistance value of RB, that is, $RB = 2RA$.
3. Use the calculated resistance values of RA and RB to make resistor selections that match (as closely as possible) the resistance of commonly available 1%, 1/10 W standard resistors.
4. Install the resistors. (See Figure 6-2 for resistor locations).

C. SELECTING CUSTOM LOW-PASS CUT-OFF FREQUENCIES.

Cut-off frequencies for a 100 Hz to 20 kHz low-pass filter range can be selected. To establish a desired -5% cut-off (corner) frequency for a customized low-pass, 2-pole Butterworth filter:

1. Select a desired cut-off frequency and, using Figure 6-4, first determine the resistance value of resistors RC and RD. Both are the same in value ($RC = RD$).
2. Use the value to select resistors that match (as closely as possible) the resistance of commonly available $\pm 1\%$, 1/10 W standard resistors.
3. Install the resistors. (See Figure 6-2 for resistor locations).

**ENDEVCO 2775AM4
INSTRUCTION MANUAL**

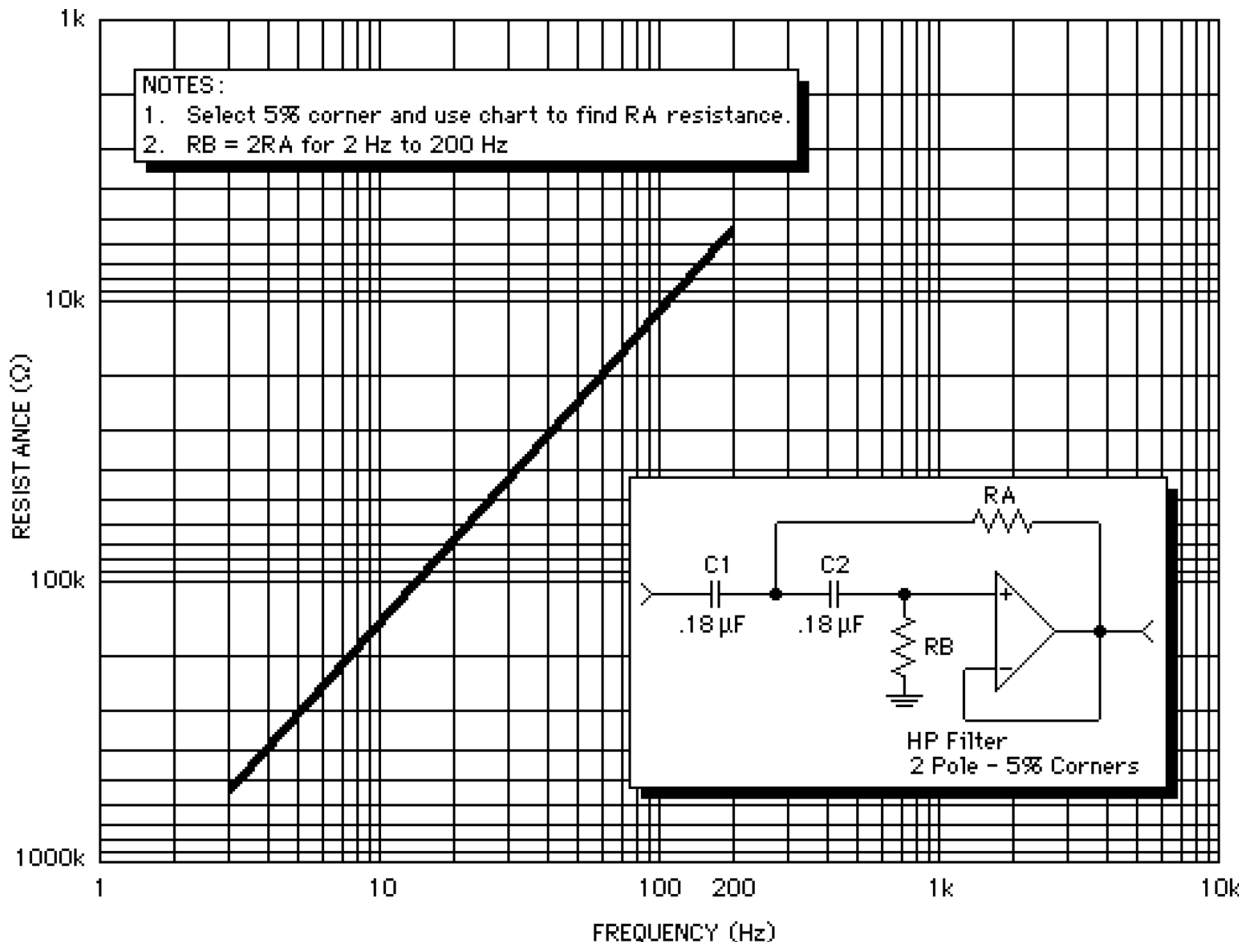

FIGURE 6-3: HIGH PASS FILTER RESISTOR SELECTION CHART

NOTE: Three DIP programming jumpers are provided for user installation as needed. Two jumpers are always used, and the third is used only when a bandpass filter is selected.

NOTE: When only a high-pass or a low-pass filter is selected, the third programming jumper may be stored in the SP (spare) position.

**ENDEVCO 2775AM4
INSTRUCTION MANUAL**

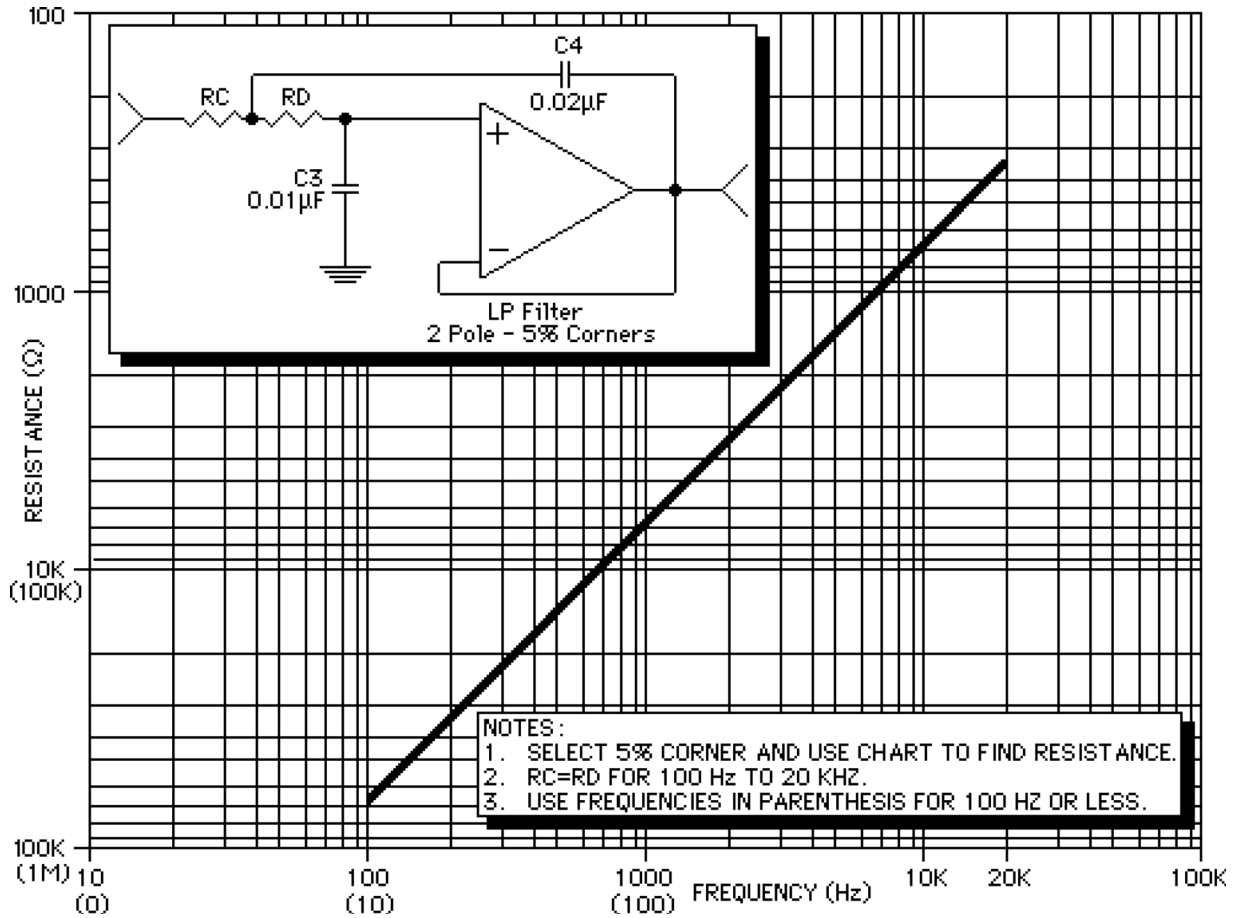

FIGURE 6-4: LOW PASS FILTER RESISTOR SELECTION CHART

4. REMOTE CHARGE CONVERTER

The Model 2771A-X remote charge converter (RCC) is an electronic device that converts the signal from a high impedance PE device to a low impedance voltage source. The RCC can be placed close to transducer at a remote location to drive long lines through hostile electrical environments with far less noise pick-up than would be possible with high impedance sources. Endevco RCCs use a two wire system that allows both power and signal to be transmitted on the same line.

The Model 2775AM4 provides the constant current power source at the REMOTE input to the unit adjustable from 0.5mA to 20mA. The 2771A requires a minimum of 4mA to 20mA for proper operation. There are frequency and voltage limitations when driving extremely long lines see section 3.4.13 for remote input interface factors.

There are three gain ranges for the Model 2771A-X RCC and they are as follows:

2771A-01	Attenuation of 0.1 mV/pC +1% -2%
2771A-1	Unity gain of 1 mV/pC +1% -2%
2771A-10	Gain of 10 mV/pC +1% -5% marked with gain

ENDEVCO 2775AM4 INSTRUCTION MANUAL

NOTE: The 2771A is an inverting device. The output is 180 degrees out of phase with the input.

A. KEY FEATURES

1. Up to 30,000 pF source capacitance
2. Operates down to 100 K Ω source resistance
3. 10 V pk-pk output minimum
4. Wide frequency response 1Hz to 50kHz (-01 & -1) -3dB @ 0.2Hz
5. (-10) frequency response of 5Hz to 50kHz -3db @ 1Hz
6. Wide temperature range -40°C to +100°C
7. 10-32 input connector and BNC output connector
8. Rugged construction, cold rolled steel case hot solder dipped

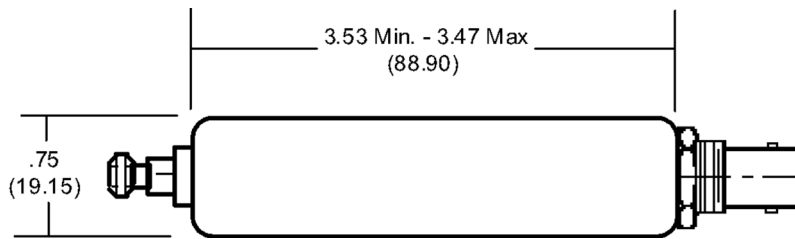

FIGURE 6-5: 2771A DIMENSIONS

B. 2771A TESTING WITH THE 2775AM4

The 2771A RCC with the 2775AM4 Signal Conditioner comprises a system. The system gain accuracies are a combination of the two devices. The 2771A-01/-1 converters are rated at +1% -2% and the 2775AM4 is rated at +1.5% accuracy. The system gain accuracy would be +2.5% and -3.5% un-calibrated. The accuracy and tolerances of the test setup and equipment must also be considered. The following procedure for checking the Model 2771A may be used for incoming inspection and for periodic calibration. The 2771A must be tested with a Model 2775AM4 or other properly rated constant current source.

C. TEST EQUIPMENT

Refer to the equipment list on page one of section 5. Hook up the equipment in accordance with figure 6-6.

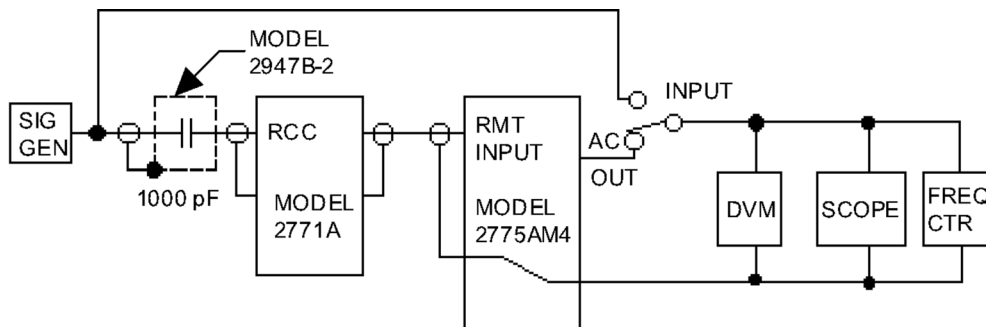

FIGURE 6-6: 2771A/2775AM4 TEST SETUP

**ENDEVCO 2775AM4
INSTRUCTION MANUAL**

**ENDEVCO 2775AM4
INSTRUCTION MANUAL**

D. INITIAL CONDITIONS

2775AM4 SETUP

Sensitivity switch to	- 1.00 (enter actual -10 gain)
Sensitivity multiplier	- x.1 (-01),x1(-1),x10(-10)
Full scale g	- 1Kg
Function	- OP
Filter	- OUT
Input isolation	- GND
LO freq	- 2Hz
Set AC output to 1Vpk	

NOTE: For best gain accuracy, the AC ADJ must be calibrated as follows:

1. Set FUNCTION switch to OUT CAL.
2. Adjust AC OUT for exactly one-tenth the measured ac amplitude at U17 pin 7. Set the FUNCTION switch to OP.

E. FULL SCALE RANGE TEST 2771A-1

Apply a 1KHz 707mV rms (1Vpk) sine wave signal through the 1000pF capacitor to the input of the RCC. The 2775AM4 AC output should be 707mV rms undistorted sine within +2.5% & -3.5% of the input.

Switch the full scale range to 100g and decrease the input signal to 70.7mV rms. The AC output should be 707mV rms +2.5% -3.5%.

F. NOISE TEST

Reduce the input to zero by turning off the oscillator or by grounding the input to the capacitor. Measure the noise at the 2775AM4 AC output with the true rms voltmeter. The noise should be less than 15mV rms broadband noise with 1000pF source capacitance.

G. FREQUENCY RESPONSE

Set the full scale switch to 1000g and adjust the input for 707mV at the 2775AM4 AC output. Change the oscillator frequency from 2Hz to 50kHz referenced to 1kHz with a tolerance of +5%. The 2771A-10 is 5Hz to 50kHz +5%.

H. GAIN ACCURACY TEST

Apply a 1kHz 707mV rms sine signal through the capacitor to the RCC input. Measure the RCC output from a BNC tee connector with a DVM. The output voltage should be 707mV rms +1% -2%. This value is the actual gain tolerance of the 2771A unit. (see Figure 6-7)

I. BIAS VOLTAGE CHECK

Change the DVM to read DC volts and measure the DC bias voltage of the 2771A. The bias voltage should be between +9V and +11V DC at room temperature and between +8V and +12VDC over -40°C to +100°C.

**ENDEVCO 2775AM4
INSTRUCTION MANUAL**

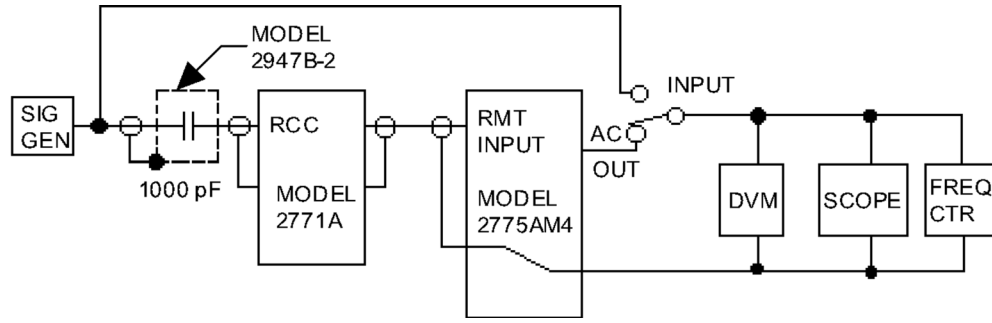

FIGURE 6-7: 2771A GAIN AND BIAS SETUP

**ENDEVCO 2775AM4
INSTRUCTION MANUAL**

**SECTION 7:
DRAWINGS AND PARTS LISTS**

1. **GENERAL**

This section includes drawings of the amplifier and the rack adapter (accessory item). Schematic drawings and electrical parts lists are in this section. Other applicable drawings and reference documents are also included.

2. **PARTS LISTS**

The following parts lists (which are keyed to the assembly drawings) are contained in this section:

Parts List

Signal Conditioner Circuit Board Assembly
P/N 27489

Rear Panel Circuit Board Assembly,
P/N 26476

Front Panel Circuit Board Assembly,
P/N 26563

Signal Conditioner Final Assembly,
P/N 92775AM4

Errata Sheet - Signal Conditioner,
P/N 92775AM4

3. **DRAWINGS**

The following schematics and assembly drawings are in this section:

Description

Signal Conditioner Final Assembly, 92775A

Signal Conditioner Circuit Board Assembly, 27489

Front Panel Circuit Board Assembly, 26563

Rear Panel Circuit Board Assembly, 26476

Signal Conditioner Schematic Diagram, SC2775AM4

Rack, 4948-C

Rack Adapter Schematic, 4948-501C

**ENDEVCO 2775AM4
INSTRUCTION MANUAL**

Calibration Check Sheet

Date: _____

2775AM4 Serial No. _____

Power Supply

+24 Vdc $\pm 7\%$	_____	+5 Vdc $\pm 6\%$	_____
+15 Vdc $\pm 6\%$	_____	-15 Vdc $\pm 6\%$	_____

Out Cal

Frequency 950-1050 Hz	_____
DC OUTPUT 10.00 Vdc ± 150 mVdc	_____
AC ADJ (A2R4) ccw greater than 7.07 Vrms	_____
AC ADJ (A2R4) cw less than .707 Vrms	_____

Test Input Check for a full scale output of approximately 7.07 Vrms.

Ext Cal Input	AC OUTPUT 6.93-7.21 Vrms	_____
	SERVO OUTPUT 6.93-7.21 Vrms	_____

Max Current Out

AC OUTPUT no load _____ Vrms	with load _____ Vrms	1% max.
SERVO OUTPUT no load _____ Vrms	with load _____ Vrms	1% max.
DC OUTPUT no load _____ Vrms	with load _____ Vrms	1% max.

Noise/DC Offset

AC OUTPUT 50 mVrms max _____	DC offset 20 mVdc max.	_____
SERVO OUTPUT 20 mVrms max	DC offset 17 mVdc max.	_____
DC OUTPUT- DC offset 30 mVdc max.		_____
METER READING less than 2%		

Note: The PE INPUT must be capped with a non-shorting cap.

**ENDEVCO 2775AM4
INSTRUCTION MANUAL**

Model 2775AM4 Calibration

PE Gain Accuracy

Accuracy will be $\pm 1.5\%$ using shielded 1000 ± 1 pF capacitor
or $\pm 2.0\%$ if the EXT CAL INPUT is used for calibration.

Limits: $\pm 2\% = 6.93-7.21$ Vrms $\pm 1.5\% = 6.96-7.18$ Vrms

INPUT mVrms	FULL SCALE switch	AC OUTPUT reading	INPUT mVrms	FULL SCALE switch	AC OUTPUT reading	SERVO reading
2121.0	3K	_____	707.0	1K	_____	
2121.0	300	_____	707.0	100	_____	
2121.0	30	_____	707.0	10	_____	
2121.0	3	_____	707.0	1	_____	
212.1	300	_____	70.7	100	_____	_____
212.1	30	_____	70.7	10	_____	_____
212.1	3	_____	70.7	1	_____	_____
212.1	0.3	_____	70.7	0.1	_____	_____
21.21	30	_____	7.07	10	_____	
21.21	3	_____	7.07	1	_____	
21.21	0.3	_____	7.07	0.1	_____	

Sensitivity Switch Test

SENSITIVITY switch	AC OUTPUT reading
2.00	_____
4.00	_____
6.00	_____
8.00	_____
10.00	_____
10.99	_____

PE Frequency Response

		1 KHz	-5%	-30%
Low Freq	2 Hz deviation ref	_____ Hz	_____ Hz	
High Freq	FULL SCALE 1 ref	_____ kHz	_____ kHz	
	FULL SCALE 3 ref	_____ kHz	_____ kHz	
	FULL SCALE 10	ref	_____ kHz	_____ kHz
	FULL SCALE 30	ref	_____ kHz	_____ kHz
	FULL SCALE 100	ref	_____ kHz	_____ kHz
	FULL SCALE 300	ref	_____ kHz	_____ kHz

**ENDEVCO 2775AM4
INSTRUCTION MANUAL**

Model 2775AM4 Calibration

Remote Gain Accuracy

FULL SCALE switch	AC OUTPUT reading
300	_____ Vrms
100	_____ Vrms
30	_____ Vrms
10	_____ Vrms
3	_____ Vrms
1	_____ Vrms

Remote Frequency Response

		1 KHz	-5%	-30%
Low Freq	0.5 Hz deviation	ref	_____ Hz	_____ Hz
High Freq	FULL SCALE 1	ref	_____ kHz	_____ kHz
	FULL SCALE 3	ref	_____ kHz	_____ kHz
	FULL SCALE 10	ref	_____ kHz	_____ kHz
	FULL SCALE 30	ref	_____ kHz	_____ kHz
	FULL SCALE 100	ref	_____ kHz	_____ kHz
	FULL SCALE 300	ref	_____ kHz	_____ kHz

Remote Noise

AC OUTPUT	200 mVrms max	_____
SERVO OUTPUT	2 mVrms max	_____
METER READING	less than 5%	_____

Note: REMOTE INPUT must be loaded with 250 ohm resistor and a 5000 pF capacitor in parallel.

Constant Current Adjust

Minimum current less than 0.5mA	_____ mA
Maximum current greater than 20mA	_____ mA
Constant current set to:	_____ mA

Notes:
